

■ Power transformer section

POWER SUPPLY BLOCK

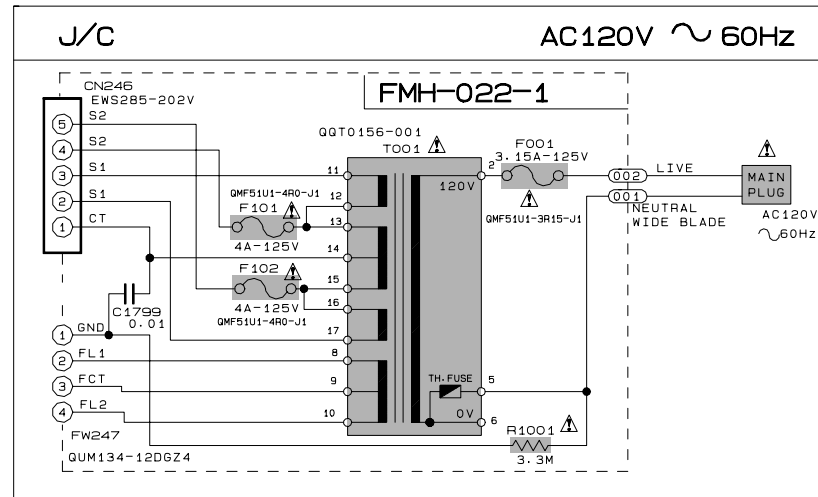

POWER SUPPLY BLOCK

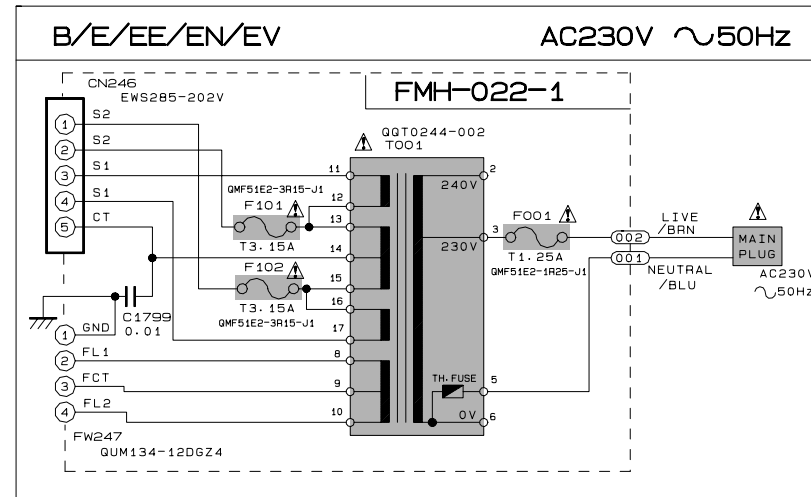

EXPLANATION OF OVERALL SCHEMATICS

MODEL MX-J30/CA-MXJ30/MX-J35R/CA-MXJ35R
MX-J330/CA-MXJ330

SHEET NUMBER	MODEL NUMBERS TO BE APPLIED	CIRCUITS DESCRIPTION
1/9	MX-J30/CA-MXJ30/MX-J35R CA-MXJ35R/MX-J330/CA-MXJ330	. PRIMARY WITH MAIN TRANSFORMER
2/9	MX-J30/CA-MXJ30/MX-J35R CA-MXJ35R/MX-J330/CA-MXJ330	. DC REGULATORS/AUDIO OUTPUT
3/9	MX-J30/CA-MXJ30/MX-J35R CA-MXJ35R/MX-J330/CA-MXJ330	. EXTERNAL INPUT. SOURCE SELECTOR SWITCH
4/9	MX-J30	. TUNER RF/IF/FM MULTIPLEX (ONLY FOR J-C-U-UB-UP-UR-US-UT-UV-UX-UY-A)
5/9	CA-MXJ30/CA-MXJ35R/CA-MXJ330	. TUNER RF/IF/FM MULTIPLEX (ONLY FOR B-E-EN-EV)
6/9	MX-J30	. TUNER RF/IF/FM MULTIPLEX (ONLY FOR EE)
7/9	MX-J30	. POLAR STEREO MULTIPLEX (ONLY FOR EE)
8/9	MX-J30/CA-MXJ30/MX-J35R CA-MXJ35R/MX-J330/CA-MXJ330	. FL DISPLAY. USER CONTROL KEYS
9/9	MX-J30	. MIC AMP. ECHO CIRCUIT (ONLY FOR U/UB/UP/UR-US/UT/UV-UX-UY)

POWER SUPPLY BLOCK

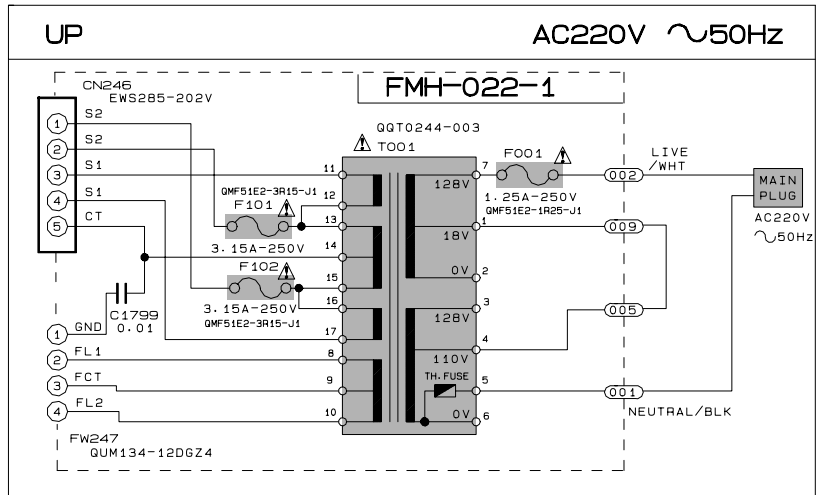

POWER SUPPLY BLOCK

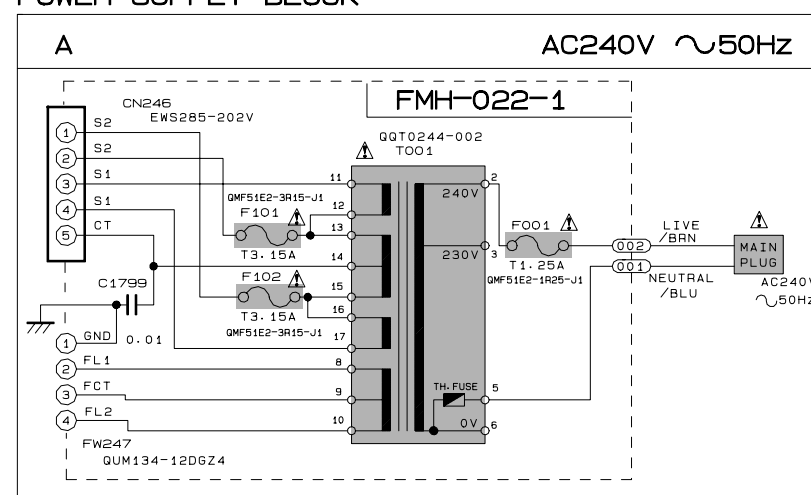

POWER SUPPLY BLOCK

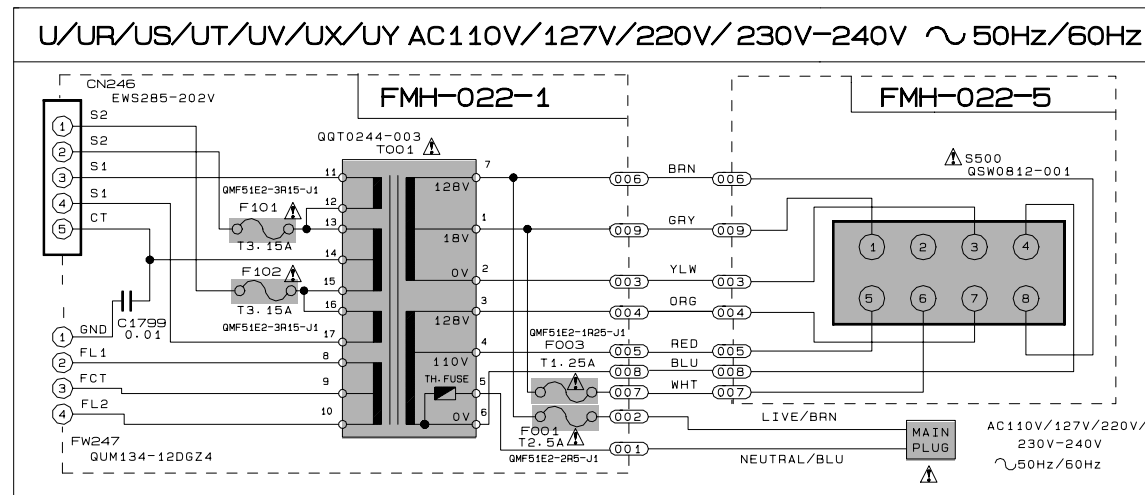

VOLTAGE SELECTOR LOCATION

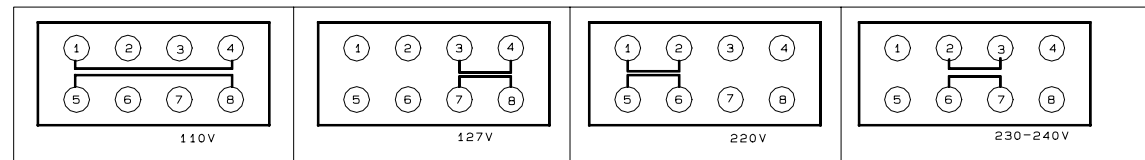

VERSION CODES

- J : U. S. A.
- C : CANADA
- B : U. K.
- E : CONTINENTAL EUROPE
- EE : RUSSIA
- EN : NORDIC COUNTRIES
- EV : EASTERN EUROPE
- A : AUSTRALIA
- UV : VIETNAM
- UP : KOREA
- UR : BRAZIL
- US : SINGAPORE
- UT : TAIWAN
- UX : SAUDI ARABIA
- U : UNIVERSIAL EXCEPT ALL OF ABOVE
- UY : ARGENTINA

▲ Parts are safety assurance parts.
When replacing those parts make
sure to use the specified one.

Power amplifier & Regulator section

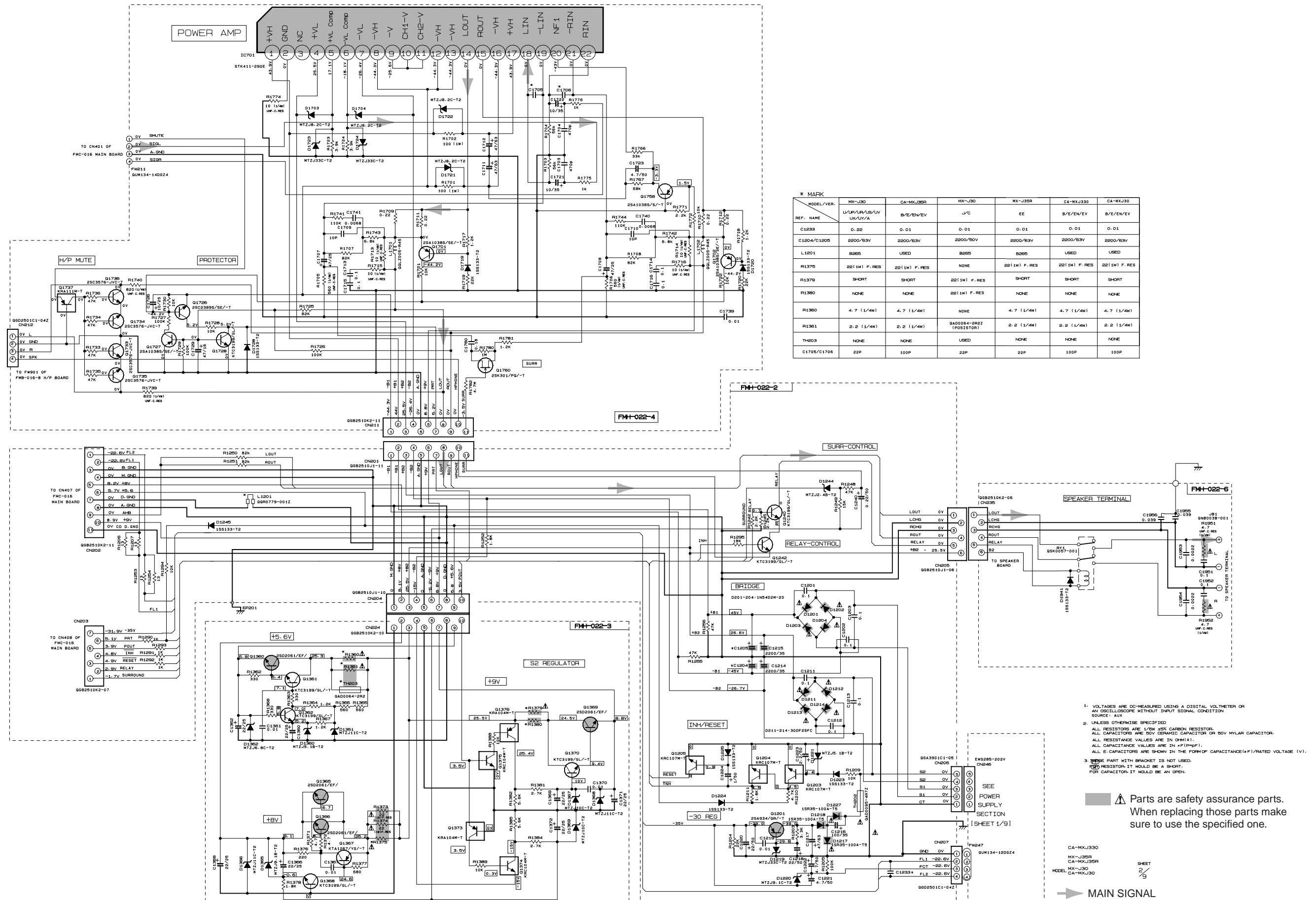

* MARK

MODEL/VER.	MX-J30	CA-MXJ30R	MX-J30	MX-J30R	CA-MXJ330	CA-MXJ30
REF. NAME	L/AP/AR/AS/AV UK/UY/A	B/E/EN/VE	J/C	EE	B/E/EN/VE	B/E/EN/VE
C1233	0.22	0.01	0.01	0.01	0.01	0.01
C1204/C1205	2200/33V	2200/33V	2200/50V	2200/33V	2200/33V	2200/33V
L1801	B265	USED	B265	B265	USED	USED
R1375	22(1W) F.RES	22(1W) F.RES	NONE	22(1W) F.RES	22(1W) F.RES	22(1W) F.RES
R1379	SHORT	SHORT	22(1W) F.RES	SHORT	SHORT	SHORT
R1380	NONE	NONE	22(1W) F.RES	NONE	NONE	NONE
R1360	4.7 (1/4W)	4.7 (1/4W)	NONE	4.7 (1/4W)	4.7 (1/4W)	4.7 (1/4W)
R1361	2.2 (1/4W)	2.2 (1/4W)	040064-PR2Z (RESISTOR)	2.2 (1/4W)	2.2 (1/4W)	2.2 (1/4W)
TH803	NONE	NONE	USED	NONE	NONE	NONE
C1705/C1706	22P	100P	22P	22P	100P	100P

- VOLTAGES ARE DC-MEASURED USING A DIGITAL VOLTMETER OR AN OSCILLOSCOPE WITHOUT INPUT SIGNAL CONDITION SOURCE: AUX
- UNLESS OTHERWISE SPECIFIED ALL RESISTORS ARE 1/8W 5% CARBON RESISTOR. ALL CAPACITORS ARE 50V CERAMIC CAPACITOR OR 50V MYLAR CAPACITOR. ALL CAPACITANCE VALUES ARE IN μF(MPF). ALL RESISTANCE VALUES ARE IN Ω(MH). ALL E-CAPACITORS ARE SHOWN IN THE FORM OF CAPACITANCE+(F)/RATED VOLTAGE (V).
- THE PART WITH BRACKET IS NOT USED. RESISTOR IT WOULD BE A SHORT. FOR CAPACITOR IT WOULD BE AN OPEN.

Parts are safety assurance parts. When replacing those parts make sure to use the specified one.

CA-MXJ330
MX-J30R
CA-MXJ30R
MX-J30
CA-MXJ30

SEE POWER SUPPLY SECTION (SHEET 1/91)
MAIN SIGNAL

TUNER Section (For Ver.J,C,U,A)

FMC-016-1(2/2)

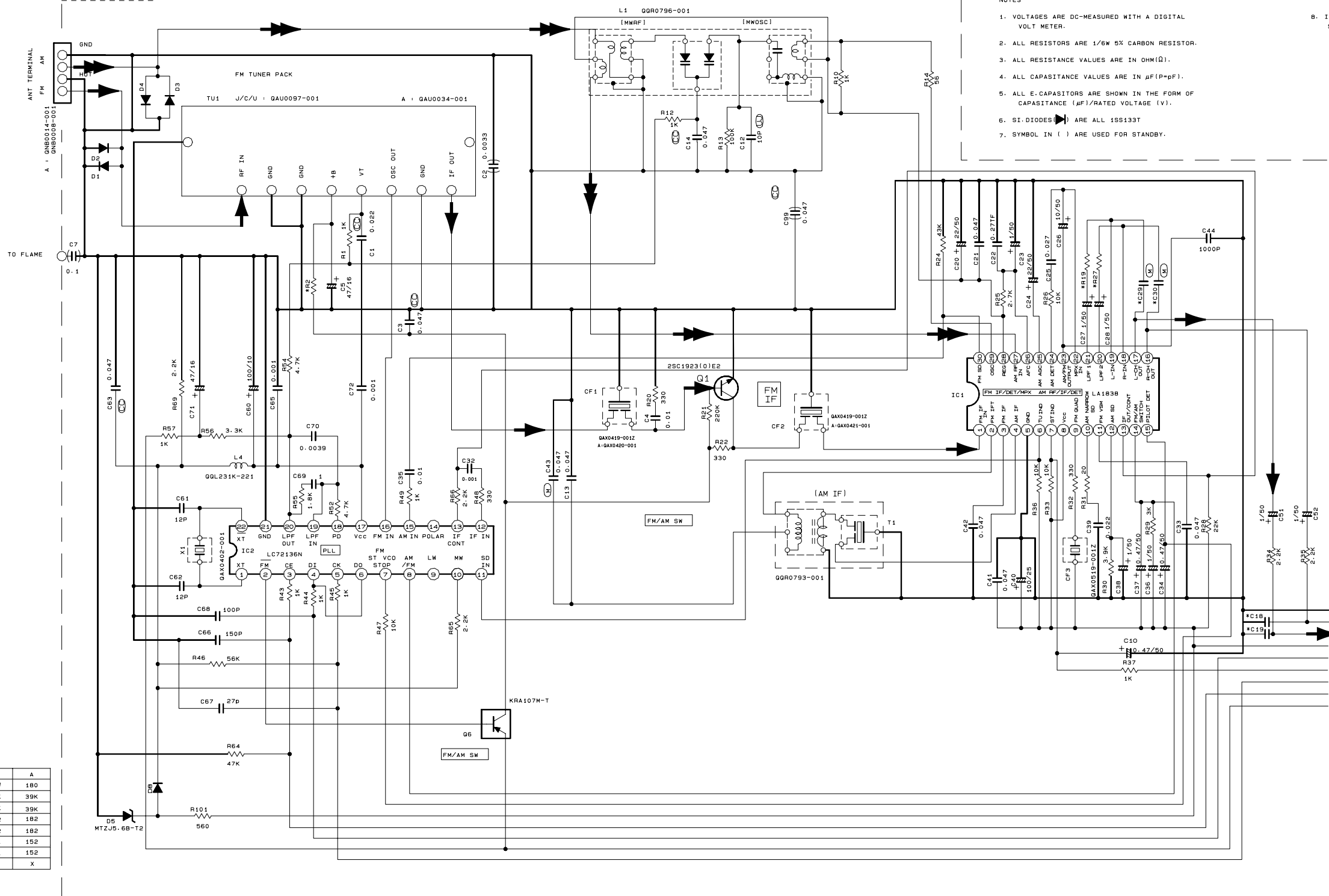

- NOTES
1. VOLTAGES ARE DC-MEASURED WITH A DIGITAL VOLT METER.
 2. ALL RESISTORS ARE 1/6W 5% CARBON RESISTOR.
 3. ALL RESISTANCE VALUES ARE IN OHM(Ω).
 4. ALL CAPACITANCE VALUES ARE IN μF(P-pF).
 5. ALL E-CAPACITORS ARE SHOWN IN THE FORM OF CAPACITANCE (μF)/RATED VOLTAGE (V).
 6. SI-DIODES ARE ALL 1SS133T
 7. SYMBOL IN () ARE USED FOR STANDBY.

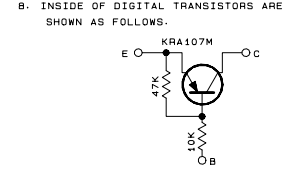

	J/C	U	A
R2	B/W	B/W	100
R19	62K	62K	39K
R27	62K	62K	39K
C29	222	152	102
C30	222	152	102
C18	471	471	152
C19	471	471	152
C44	0	0	X

0 : USED
X : NOT USED

CONDITION	PIN NO.	1	2	3	4	5	6	7	8	9	10	11	12	13	14	15	16	17	18	19	20	21	22	23	24	25	26	27	28	29	30
IC1	FM NO SIGNAL	3-5	9-1	3-5	3-5	0-4	7-0	6-4	9-1	0	1-3	0-3	0-5	0-8	8	8	4-3	4-3	4-3	4-3	3-2	3-2	2-8	3-5	0	0	3-4	3-4	3-6	3-6	2-3
	FM 60dB STEREO	3-5	9-1	3-5	3-5	0	0	0-2	9-1	2-3	1-3	4-3	0	0-8	8	8-1	4-3	4-3	4-3	4-3	3-2	3-2	2-8	3-1	0	0	3-6	3-6	3-6	3-6	2-3
	AM NO SIGNAL	3-5	9-1	3-5	3-5	0	9-1	6-4	9-1	2-7	1-3	0	0	0-8	0-1	5-6	4-2	4-2	4-2	4-2	3-2	3-2	2-8	2-9	0-6	0-5	3-5	3-5	3-5	3-5	2-1
IC2	FM NO SIGNAL	2-4	0	0	5-6	4-9	5-6	8	8	3-6	3-8	8-4	0	0	0	0	2-4	4-9	0-7	0-7	7-2	0	2-6								

Tr NO.	Q1			Q6		
PIN NO.	E	C	B	E	C	B
FM 87.5MHz NO SIGNAL	0	7.4	0.8	8.4	8.3	0
AM 52KHz NO SIGNAL	0	0	0	8.5	0	8.4

Tr NO.	Q2			Q3			Q4			
PIN NO.	E	C	B	E	C	B	E	C	B	
AM 52KHz NO SIGNAL	3.5	3.5	0.3	0	0	0.7	0	0	0	0.7
AM 144KHz NO SIGNAL	3.5	3.5	3.5	0	0	0.1	0	0	0	0.1

J/C/U/A
MX-J30
SHEET
4/9



TUNER GND
TUNER R
TUNER L
TUNER +9V
DATA
MPX
CLOCK
PERIOD
Vt/FM+B

FROM EXTERNAL INPUT SOURCE

TUNER Section (For Ver.B,E,EN,EV)

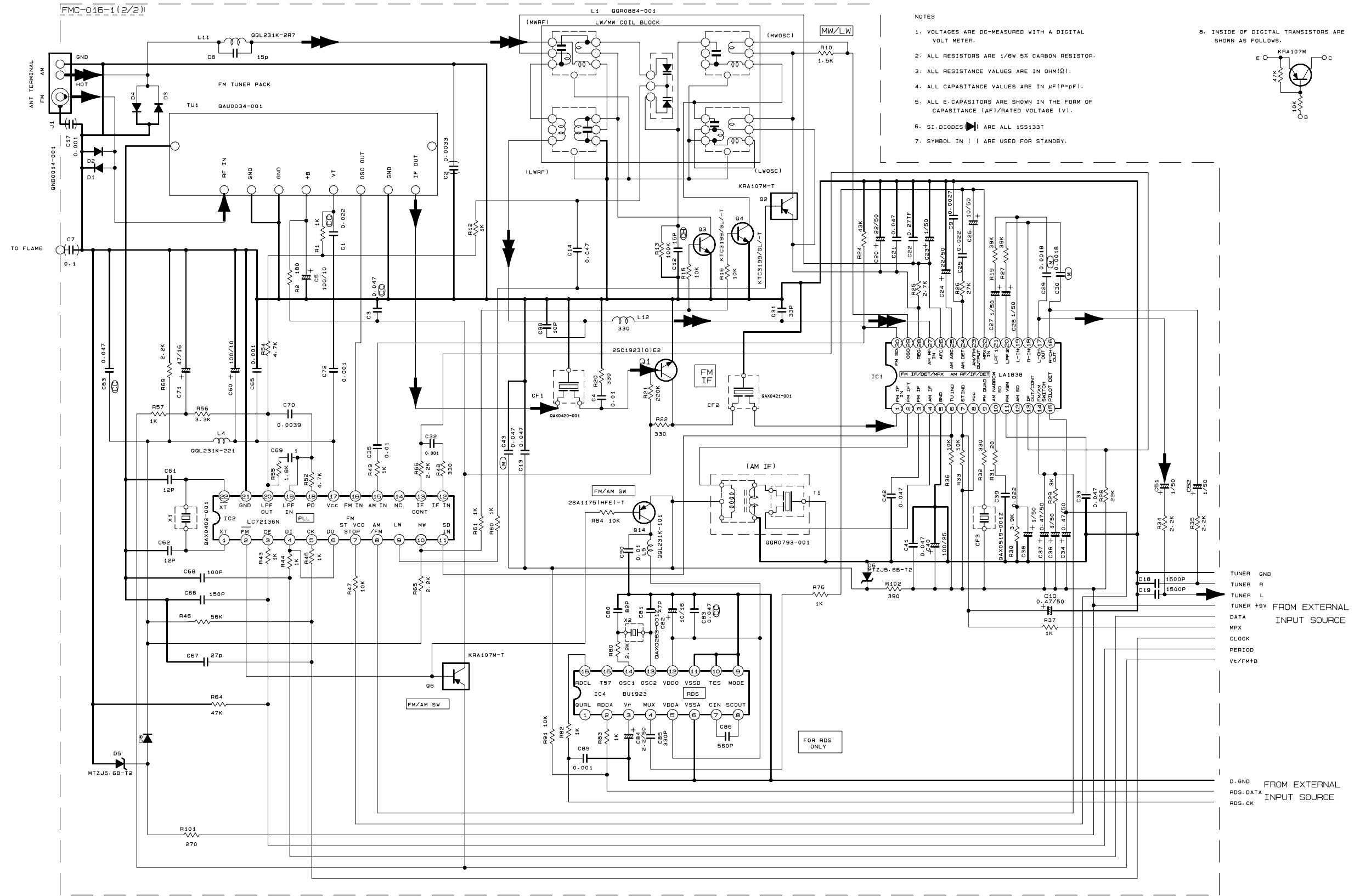

- NOTES
1. VOLTAGES ARE DC-MEASURED WITH A DIGITAL VOLT METER.
 2. ALL RESISTORS ARE 1/6W 5% CARBON RESISTOR.
 3. ALL RESISTANCE VALUES ARE IN OHM(Ω).
 4. ALL CAPASITANCE VALUES ARE IN #F(P=pF).
 5. ALL E-CAPASITORS ARE SHOWN IN THE FORM OF CAPASITANCE (#F)/RATED VOLTAGE (V).
 6. SI-DIODES ARE ALL 1SS133T
 7. SYMBOL IN () ARE USED FOR STANDBY.

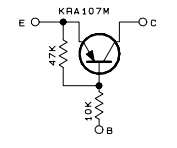

IC1	CONDITION	PIN NO.	1	2	3	4	5	6	7	8	9	10	11	12	13	14	15	16	17	18	19	20	21	22	23	24	25	26	27	28	29	30
	FM NO SIGNAL		3.5	9.1	3.5	3.5	0.4	7.0	6.4	9.1	0	1.3	0.3	0.5	0.8	8	8	4.3	4.3	4.3	4.3	3.2	3.2	2.8	3.5	0	0	3.4	3.4	3.6	3.6	2.3
	FM 60dB STEREO		3.5	9.1	3.5	3.5	0	0	0	9.1	2.3	1.3	4.3	0	0.8	8	8	4.3	4.3	4.3	4.3	3.2	3.2	2.8	3.1	0	0	3.6	3.6	3.6	3.6	2.3
	AM NO SIGNAL		3.5	9.1	3.5	3.5	0	9.1	6.4	9.1	2.7	1.3	0	0	0.8	0.1	5.6	4.2	4.2	4.2	4.2	3.2	3.2	2.8	2.9	0.6	0.5	3.5	3.5	3.5	3.5	2.1
IC2	FM NO SIGNAL		2.4	0	0	5.6	4.9	5.6	8	8	3.6	3.8	8.4	0	0	0	0	2.4	4.9	0.7	0.7	7.2	0	2.6								

Tr. NO.	01	06	02	03	04	
PIN NO.	E	C	B	E	C	B
FM 87.5MHZ NO SIGNAL	0	7.4	0.8	8.4	8.3	0
AM 522KHZ NO SIGNAL	0	0	0	8.5	0	8.4
AM 522KHZ NO SIGNAL	3.5	3.5	0.3	0	0	0.7
AM 144KHZ NO SIGNAL	3.5	3.5	3.5	0	0	0.1

B/E/EN/EV
MODEL CA-MXJ330
CA-MXJ35R
CA-MXJ30

SHEET
5/9

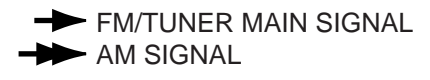

TUNER GND
TUNER R
TUNER L
TUNER +9V FROM EXTERNAL INPUT SOURCE
DATA
MPX
CLOCK
PERIOD
VC/FM+8
D. GND FROM EXTERNAL INPUT SOURCE
RDS. DATA
RDS. CK

TUNER Section (For Ver.EE)

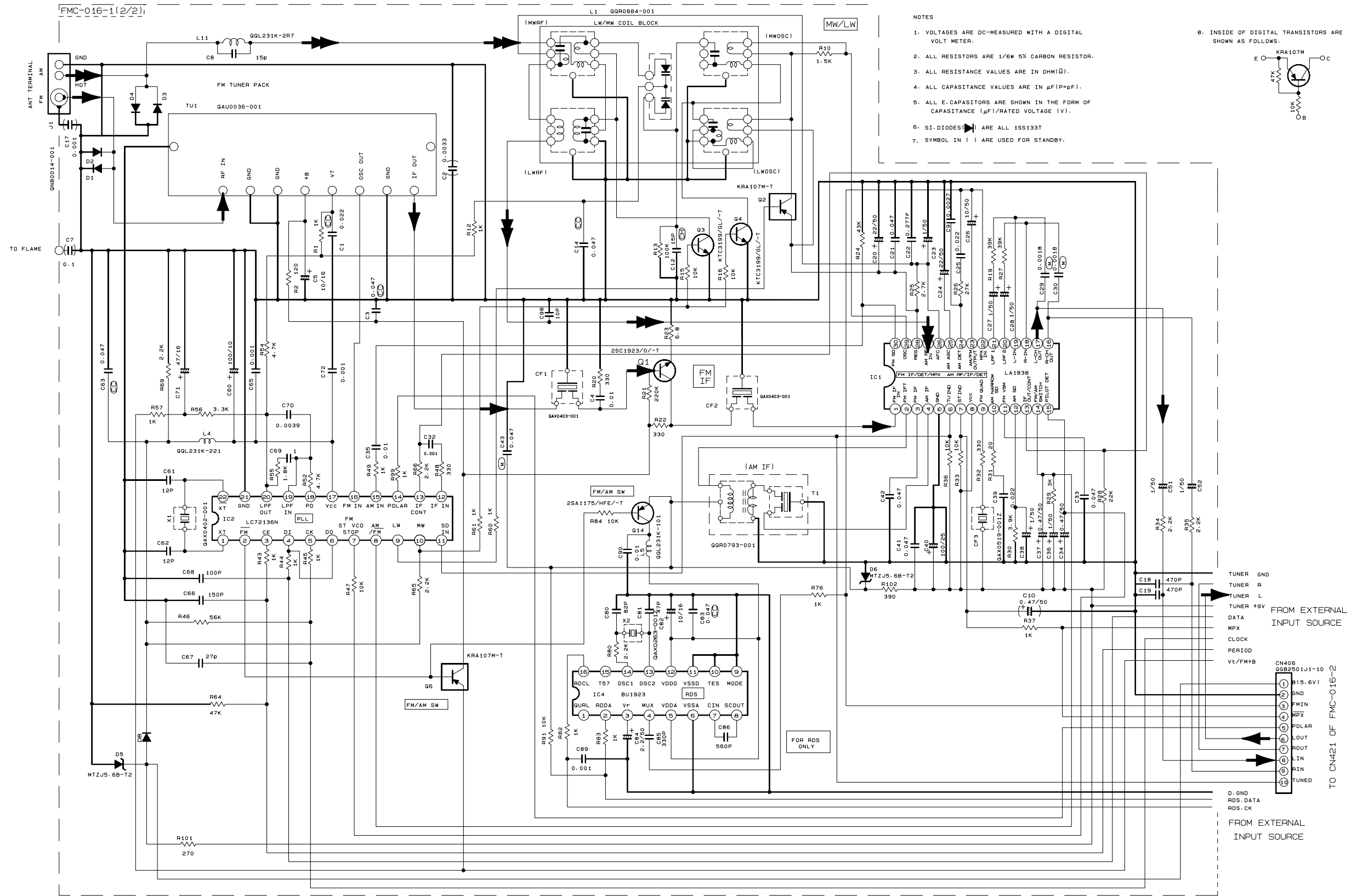

- NOTES
1. VOLTAGES ARE DC-MEASURED WITH A DIGITAL VOLT METER.
 2. ALL RESISTORS ARE 1/8W 5% CARBON RESISTOR.
 3. ALL RESISTANCE VALUES ARE IN OHM(Ω).
 4. ALL CAPACITANCE VALUES ARE IN μF(P=pF).
 5. ALL E-CAPACITORS ARE SHOWN IN THE FORM OF CAPACITANCE (μF)/RATED VOLTAGE (V).
 6. SI-DIODES (▶) ARE ALL 1SS133T
 7. SYMBOL IN () ARE USED FOR STANDBY.
 8. INSIDE OF DIGITAL TRANSISTORS ARE SHOWN AS FOLLOWS.

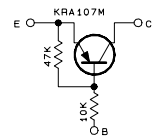

CONDITION	PIN NO.	1	2	3	4	5	6	7	8	9	10	11	12	13	14	15	16	17	18	19	20	21	22	23	24	25	26	27	28	29	30
IC1	FM NO SIGNAL	3.5	9.1	3.5	3.5	0.4	7.0	6.4	9.1	0	1.3	0.3	0.5	0.8	8	8	4.3	4.3	4.3	4.3	3.2	3.2	2.8	3.5	0	0	3.4	3.4	3.6	3.6	2.3
	FM 60dB STEREO	3.5	9.1	3.5	3.5	0	0	0.2	9.1	2.3	1.3	4.3	0	0.8	8	8.1	4.3	4.3	4.3	3.2	3.2	2.8	3.1	0	0	3.6	3.6	3.6	3.6	2.3	
	AM NO SIGNAL	3.5	9.1	3.5	3.5	0	9.1	6.4	9.1	2.7	1.3	0	0	0.8	0.1	5.6	4.2	4.2	4.2	4.2	3.2	3.2	2.8	2.9	0.6	0.5	3.5	3.5	3.5	2.5	2.1
IC2	FM NO SIGNAL	2.4	0	0	5.6	4.9	5.6	8	8	3.6	3.8	8.4	0	0	0	0	2.4	4.9	0.7	0.7	7.2	0	2.6								

Tr NO.	Q1	Q6
PIN NO.	E C B E C B	E C B E C B
FM 87.5KHZ NO SIGNAL	0 7.4 0.8	8.4 8.3 0
AM 522KHZ NO SIGNAL	0 0 0	8.5 0 8.4

Tr NO.	Q2	Q3	Q4
PIN NO.	E C B E C B E C B	E C B E C B	E C B
FM 87.5KHZ NO SIGNAL	3.5 3.5 0.3	0 0 0.7	0 0 0.7
AM 144KHZ NO SIGNAL	3.5 3.5 3.5	0 0 0.1	0 0 0.1

EE MODEL MX-J35R SHEET 6/9
MX-J30

FM/TUNER MAIN SIGNAL
AM SIGNAL

TUNER GND
TUNER R
TUNER L
TUNER +9V
FROM EXTERNAL INPUT SOURCE
DATA
MPX
CLOCK
PERIOD
Vt/FM#B
CN406 5682501J1-10
① B(5.6V)
② GND
③ FM IN
④ MPX
⑤ POLAR
⑥ LOUT
⑦ ROUT
⑧ IN
⑨ RIN
⑩ TUNED
TO CN421 OF FMC-016-2
D: GND
RDS: DATA
RDS: CK
FROM EXTERNAL INPUT SOURCE

■ POLAR section

FMC-016-2

FROM CN406 OF FMC-016-1
[TUNER SECTION]

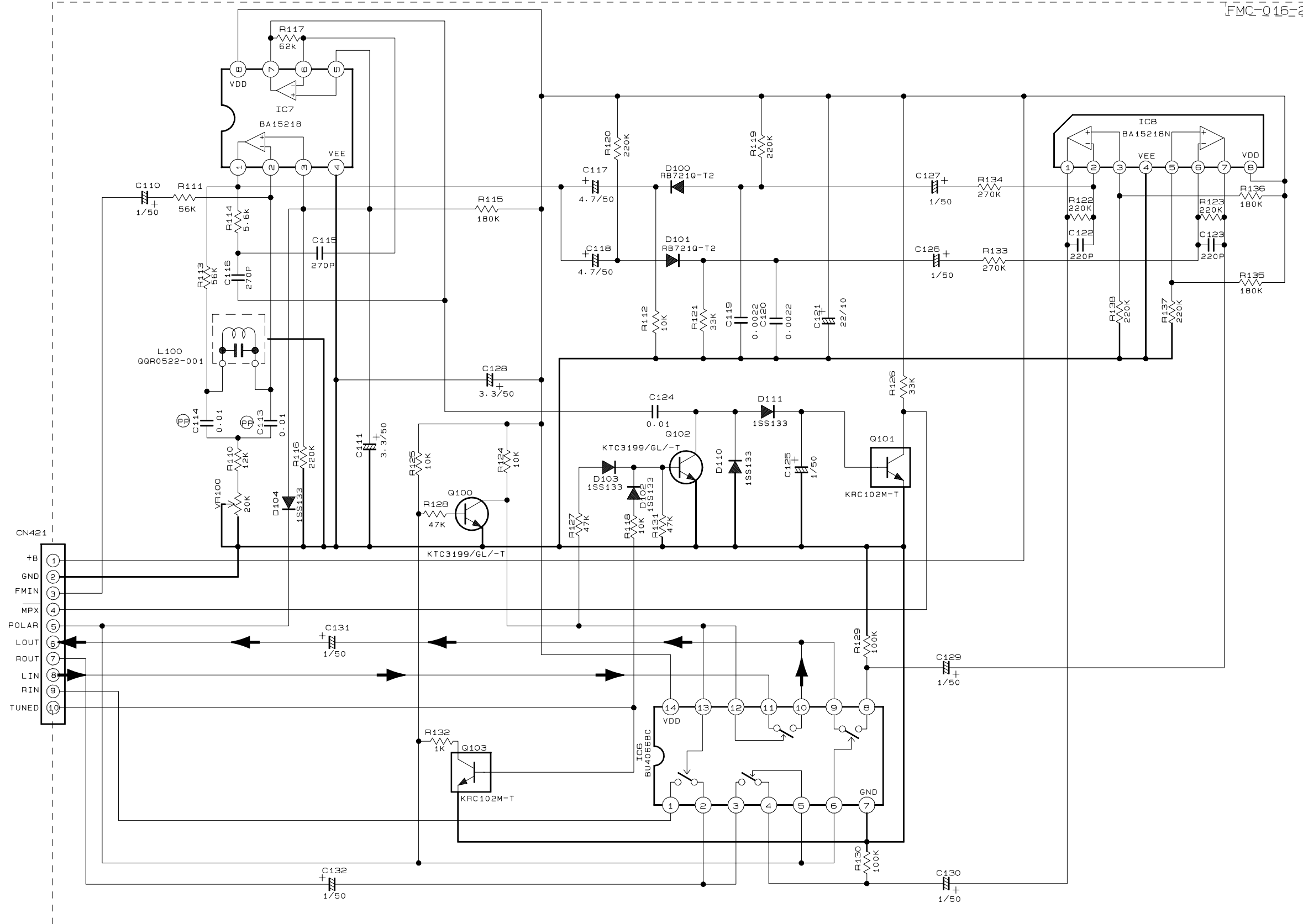

➔ TUNER MAIN SIGNAL

MODEL MX-J30 EE
MX-J35R

SHEET
7/9

FL Display & System controller Section

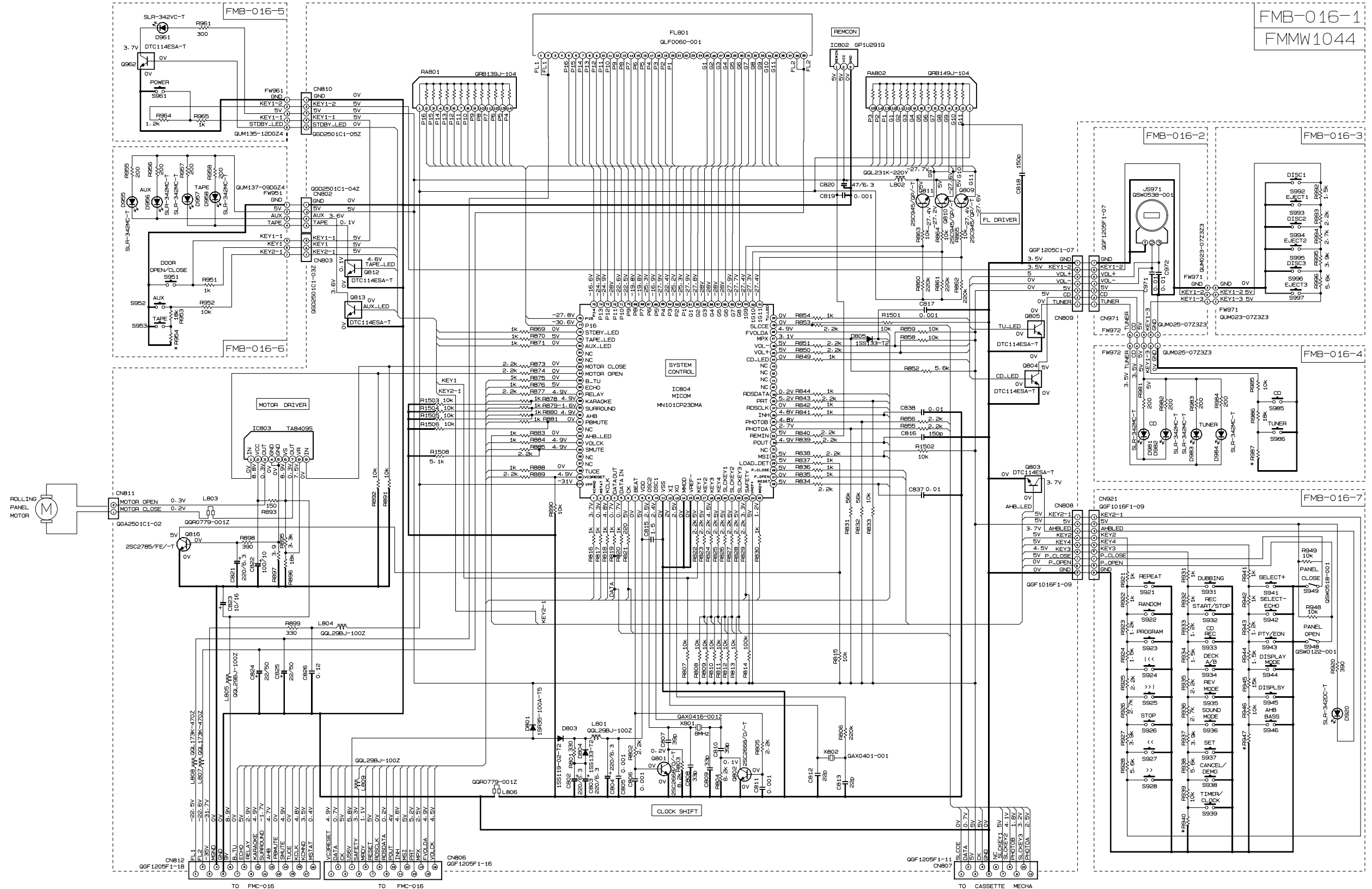

*MARK

MODEL	VERSION	R940	R947	R954	R987	S941	S942	S943	S944	R842	R844	R857	R876	R878	R1503
MX-J30	J. C	56k	56k	56k	-	-	-	-	-	-	-	-	-	-	-
	U. US. UT. UB. UP. UV	56k	-	56k	-	-	-	-	-	-	-	-	1k	1k	10k
	A	-	-	56k	-	-	-	-	-	-	-	-	-	-	-
	EE	56k	56k	-	-	-	-	-	-	-	-	-	-	-	-
	UR. UY	-	18k	-	-	-	-	-	-	-	-	-	1k	1k	10k
MX-J35R	EE	-	56k	-	-	USED	USED	USED	USED	1k	1k	10k	-	-	-
CA-MXJ30	E. EN. EV. B	-	56k	56k	-	-	-	-	-	-	-	-	-	-	-
CA-MXJ35R	E. EN. EV. B	56k	-	-	-	USED	USED	USED	USED	1k	1k	10k	-	-	-

NOTES

1. VOLTAGES ARE DC-MEASURED WITH A DIGITAL VOLT METER OR OSCILLOSCOPE WITHOUT INPUT SIGNAL. CONDITION — TAPE FB MODE
2. UNLESS OTHERWISE SPECIFIED
RESISTORS ARE 1/8W 1% CARBON RESISTOR
ALL RESISTANCE VALUES ARE IN OHM (Ω)
ALL CAPACITORS ARE CERAMIC CAPACITOR OR MYLAR CAPACITOR
ALL CAPACITANCE VALUES ARE IN pF (pF)
ALL INDUCTANCE VALUES ARE IN mH (mH)
ALL CAPACITORS ARE SHOWN IN THE FORM OF CAPACITANCE (pF/PATED VOLTAGE (V)).
ALL DIODES ARE 1S9199
ALL TACT SWITCH ARE G80674-0012

MODEL CA-MXJ330 SHEET 8/9
CA-MXJ35R
CA-MXJ30
MX-J35R
MX-J30

■ MIC & Headphone Section

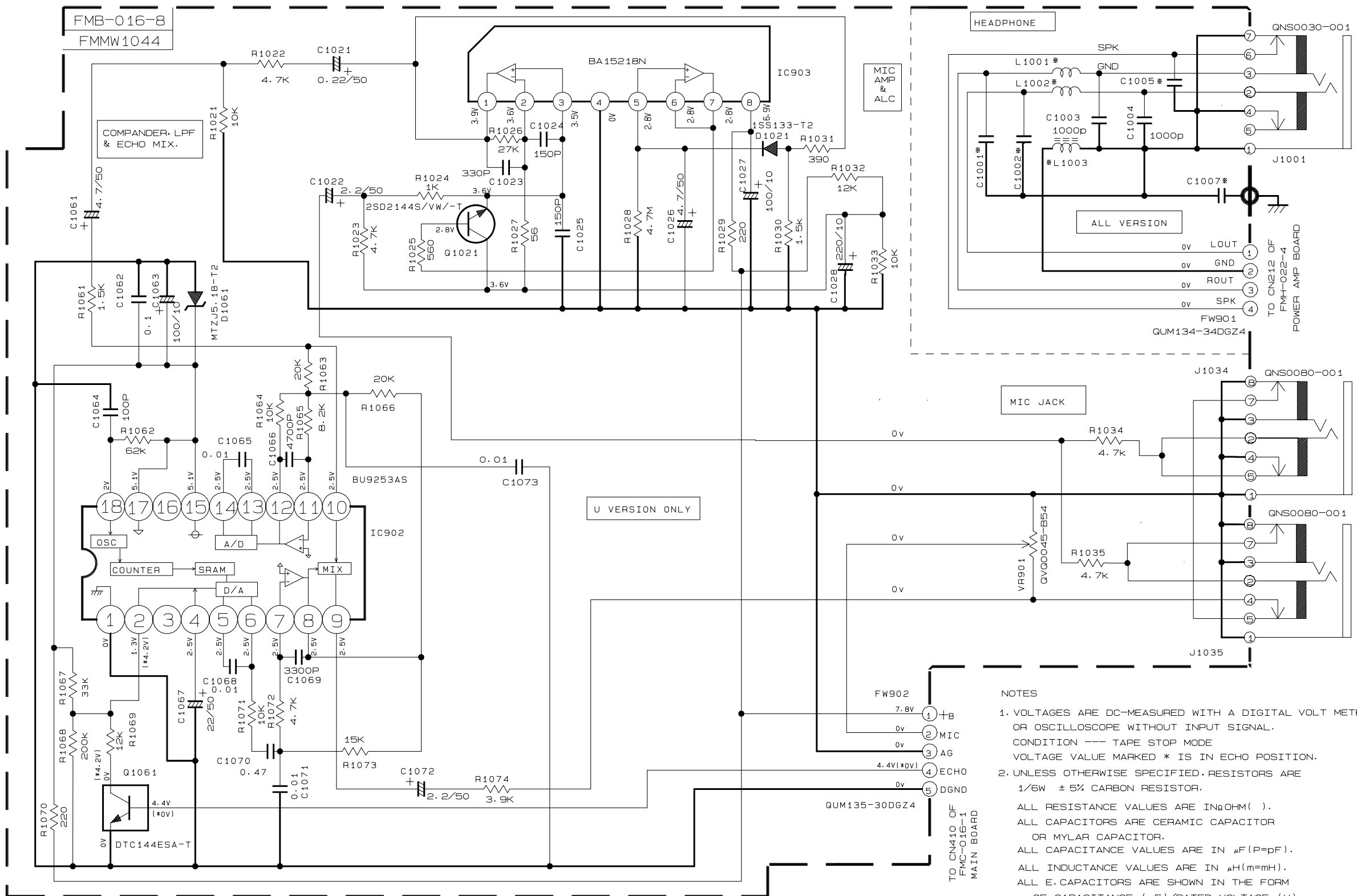

NOTES

- VOLTAGES ARE DC-MEASURED WITH A DIGITAL VOLT METER OR OSCILLOSCOPE WITHOUT INPUT SIGNAL. CONDITION --- TAPE STOP MODE. VOLTAGE VALUE MARKED * IS IN ECHO POSITION.
- UNLESS OTHERWISE SPECIFIED, RESISTORS ARE 1/6W ± 5% CARBON RESISTOR. ALL RESISTANCE VALUES ARE IN Ω OHM (). ALL CAPACITORS ARE CERAMIC CAPACITOR OR MYLAR CAPACITOR. ALL CAPACITANCE VALUES ARE IN μF (P=pF). ALL INDUCTANCE VALUES ARE IN μH (m=mH). ALL E. CAPACITORS ARE SHOWN IN THE FORM OF CAPACITANCE (μF)/RATED VOLTAGE (V). ALL DIODES ARE 1SS133T-77

* MARK

VERSION	L1001/L1002	L1003	C1001, C1002 C1005, C1007
B·E·EN·A	QQL231K-470Y	QQR0779-001Z	1000p
OTHERS	B131/B132	QQL231K-2R2Y	-

MODEL CA-MXJ330
CA-MXJ35R
CA-MXJ30
MX-J35R
MX-J30

SHEET 9 / 9

FW902 7.8V
0v
0v
4.4V(*0V)
0v
TO CN410 OF FMC-016-1 MAIN BOARD

J1034 QNS0080-001
J1035 QNS0080-001
TO CN212 OF FMC-022-4 POWER AMP BOARD

■ CD Servo & CD Mechanism control section

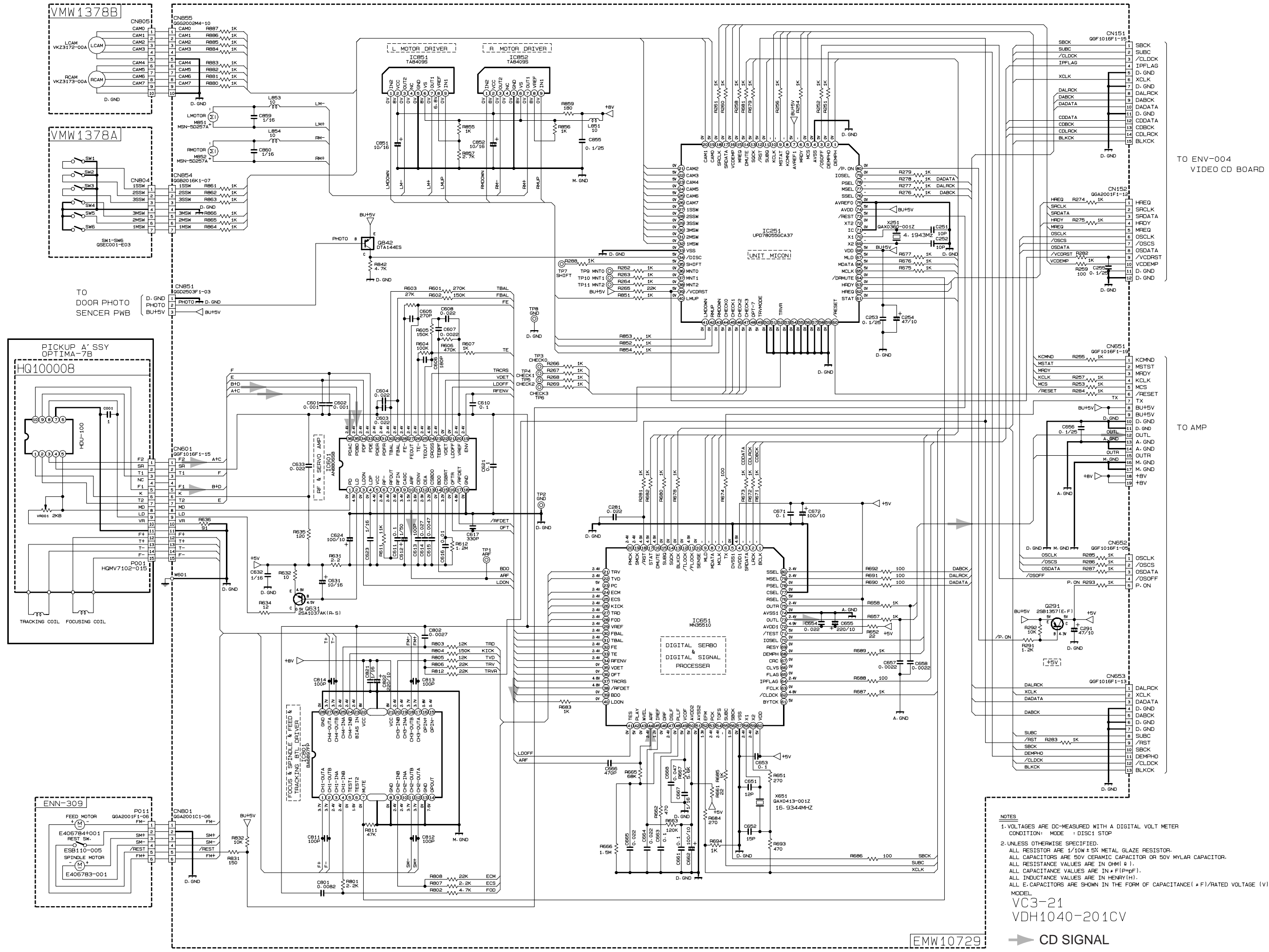

NOTES
 1. VOLTAGES ARE DC-MEASURED WITH A DIGITAL VOLT METER
 CONDITION: MODE : DISC1 STOP
 2. UNLESS OTHERWISE SPECIFIED,
 ALL RESISTOR ARE 1/10W ± 5% METAL GLAZE RESISTOR.
 ALL CAPACITORS ARE 50V CERAMIC CAPACITOR OR 50V MYLAR CAPACITOR.
 ALL RESISTANCE VALUES ARE IN OHM (Ω).
 ALL CAPACITANCE VALUES ARE IN PICO (pF).
 ALL INDUCTANCE VALUES ARE IN HENRY (H).
 ALL E-CAPACITORS ARE SHOWN IN THE FORM OF CAPACITANCE (μF)/RATED VOLTAGE (V).

MODEL
 VC3-21
 VDH1040-201CV

→ CD SIGNAL

TO ENV-004
 VIDEO CD BOARD

TO AMP

EMW10729

Head amplifier & Mechanism control section

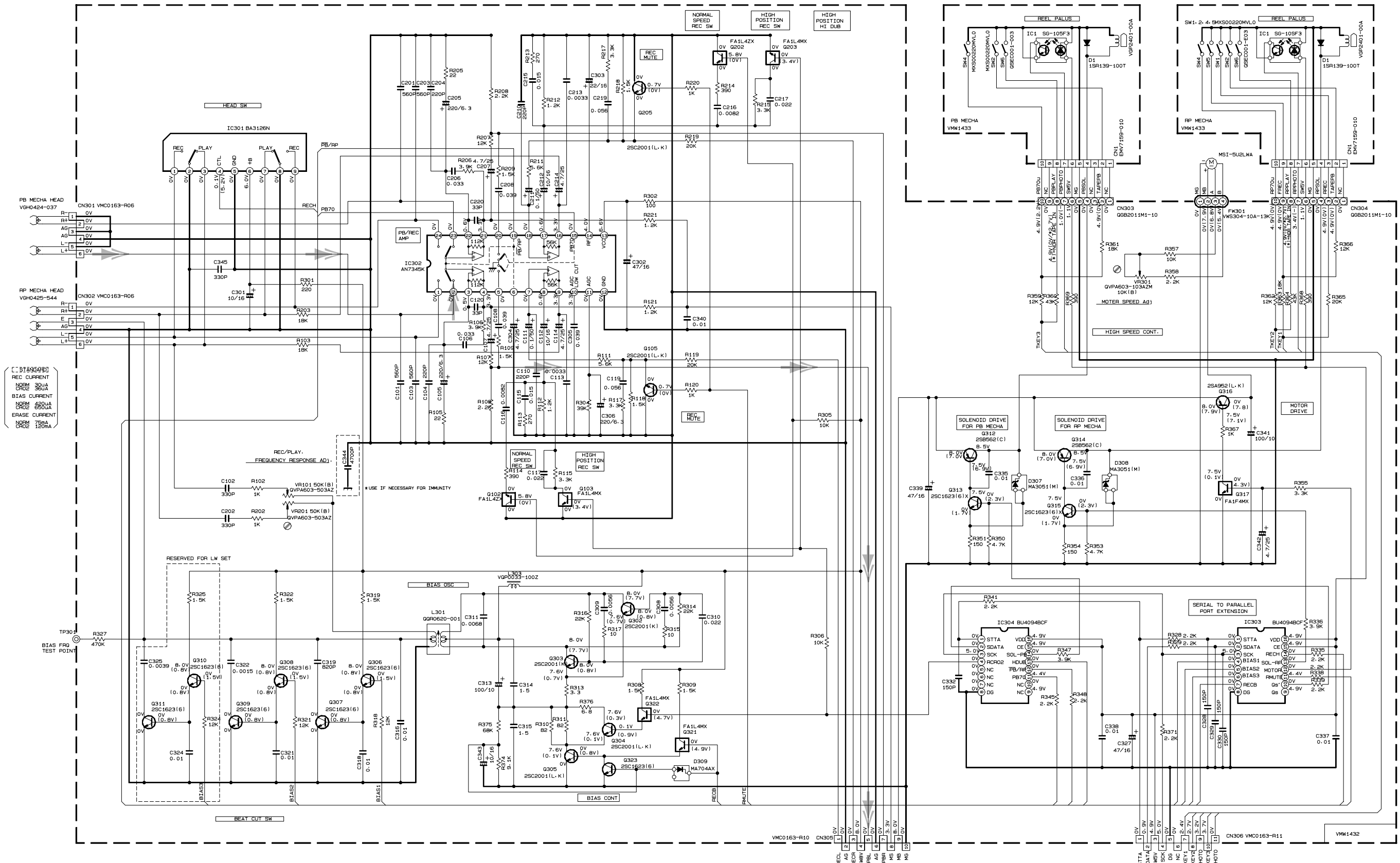

REC CURRENT
NORM 300A
CRCS 350A
BIAS CURRENT
NORM 4500A
CRCS 6500A
ERASE CURRENT
NORM 1200A
CRCS 1200A

- NOTES
- VOLTAGES ARE DC-MEASURED WITH A DIGITAL VOLT METER OR OSCILLOSCOPE WITHOUT INPUT SIGNAL. | | IS INVERT MODE
 - UNLESS OTHERWISE SPECIFIED:
ALL RESISTANCE VALUES ARE IN OHM (Ω)
ALL CAPACITORS ARE CERAMIC CAPACITOR
ALL CAPACITANCE VALUES ARE IN PICO-F (pF)
ALL INDUCTANCE VALUES ARE IN MILLI-HENRY (mH)
ALL E.CAPACITORS ARE SHOWN IN THE FORM OF CAPACITANCE (F)/RATED VOLTAGE (V).
|| PLYPROPYLENE CAPACITOR

TABLE 1-DIGITAL TR LIST

PART. NO	CONSTRUCTION	REF. NO
FA1F4M		Q317
FA1L4M		Q103/Q203
FA1L4Z		Q321/Q322

→ TAPE P.B. SIGNAL

SLC-W5
VDH1033-003PV

Disassembly method

< Main body >

■ Removing the Metal Cover (See Fig.1 to 3)

1. Remove the six A screws attaching the metal cover on the back of the body.
2. Remove the two B screws attaching the metal cover on both sides of the body.
3. Lift the metal cover on the back of the body and remove it from the body.

CAUTION: DO NOT break the front panel tab fitted to the metal cover.

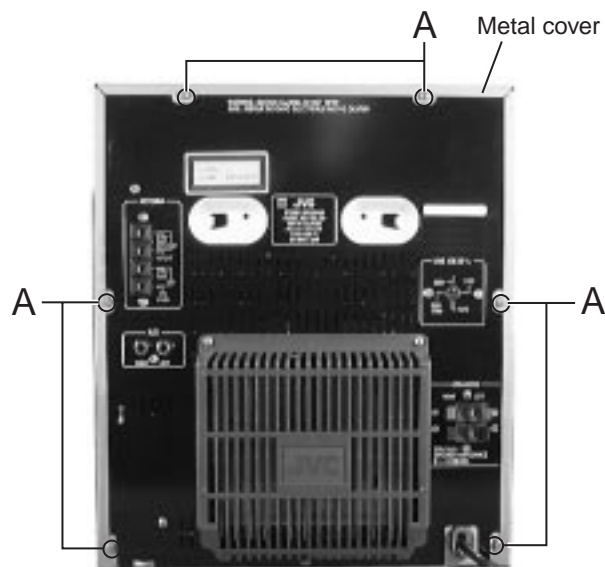

Fig.1

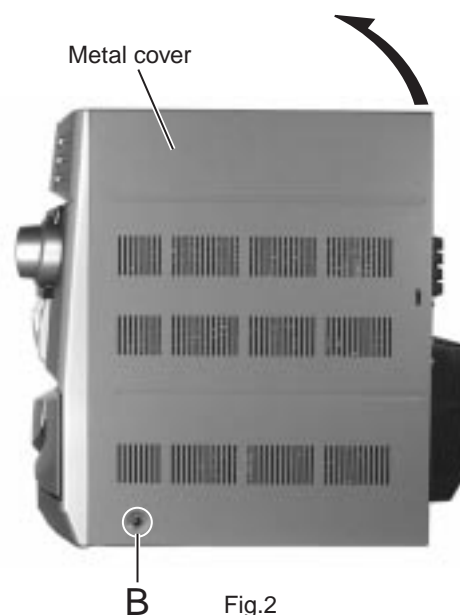

Fig.2



Fig.3

■ Removing the CD Changer Mechanism Assembly (See Fig.4 to 6)

- Prior to performing the following procedure, remove the metal cover.

1. Disconnect the connector CN404 of the card wire connecting the CD changer mechanism board to the main board.
2. Remove the two C screws on the upper side of the CD changer assembly and the two D screws on the back of the rear panel.
3. Remove the plastic rivet attaching the main board.
4. Lift and remove the CD changer mechanism assembly on the back of the body while pulling the rear panel and the front panel assembly.

* To prevent damage to the CD fitting, be sure to pull the rear panel and the front panel assembly enough to remove the CD changer mechanism.

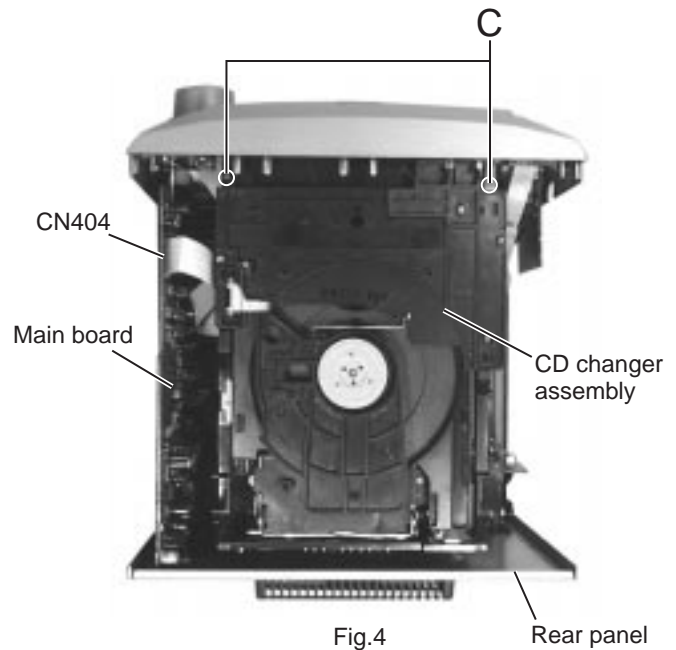

Fig.4

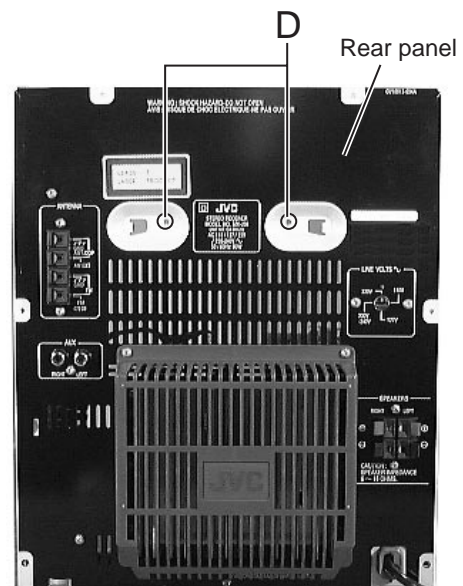

Fig.5

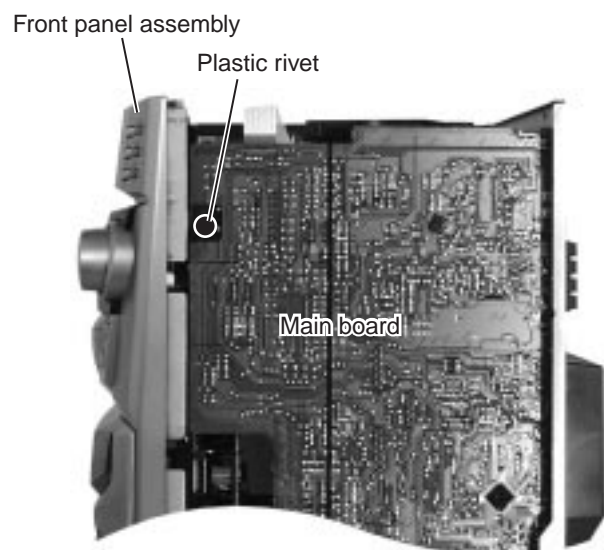

Fig.6

< Front Assembly >

■ **Removing the Front Panel Assembly**
(See Fig.7 to 9)

• Prior to performing the following procedure, remove the metal cover and CD changer mechanism assembly.

1. Disconnect the card wires from connector CN402, CN403 and CN416 on the main board.
2. Disconnect the flat wire from connector CN212 on the amplifier board.
3. Disconnect the flat wire from connector CN410 on the main board. (only Ver,U type)
4. Remove the four E screws attaching the front panel assembly on the bottom of the body.
5. Release the two joints(a) and (b) on the lower left and right sides of the body using a screwdriver, and remove the front panel assembly toward the front.

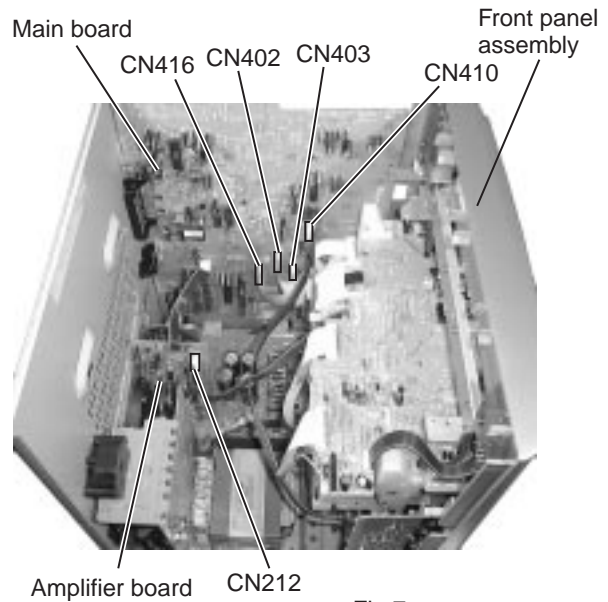

Fig.7

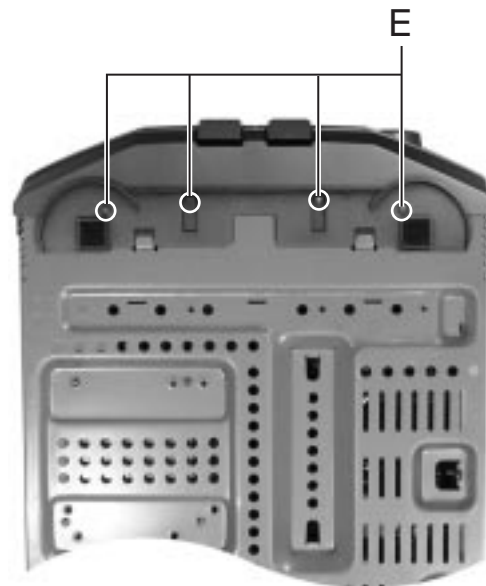
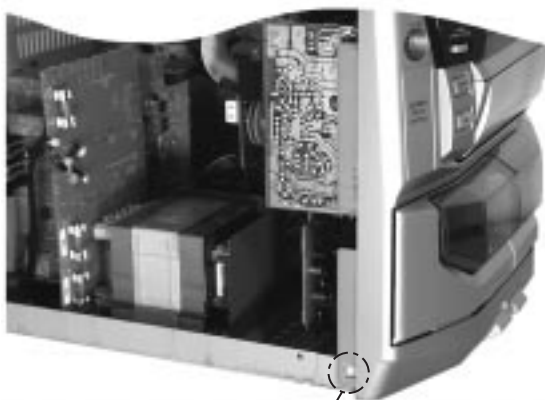

Fig.8



Joint(a)
Fig.9a



Joint(b)
Fig.9b

■ Removing the Rolling panel Panel assembly

(See Fig.10 and 11)

1. Disconnect the card wires from connector CN810, CN809, CN807, CN803, CN802 on the upper system control & FL board and on the rolling panel assembly on the reverse side of the front panel assembly
2. Remove the six F screws attaching the stay bracket.
3. Remove the four G screws attaching the rolling panel assembly.

* Disconnect the flat wire extending from the phones board through the slit of the rolling panel assembly.

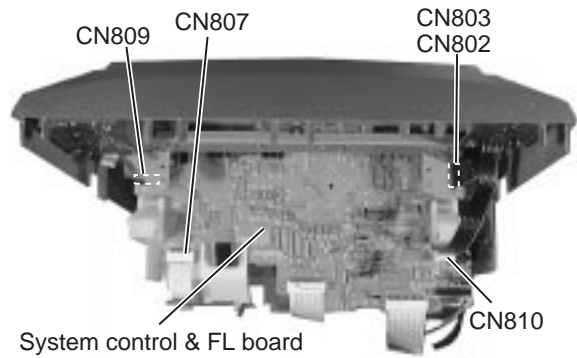

Fig.10

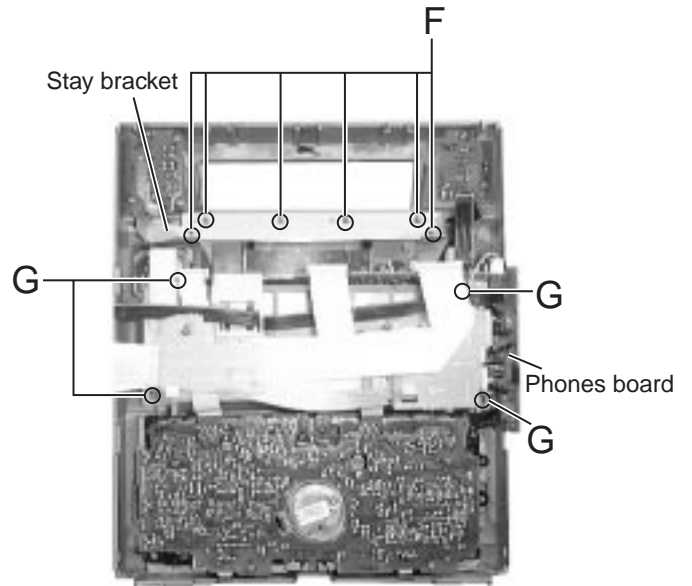

Fig.11

■ Removing the Cassette Mechanism Assembly

(See Fig.12)

- Prior to performing the following procedure, remove the rolling panel assembly.
1. Remove the four H screws and four H1 screws attaching the cassette mechanism assembly.

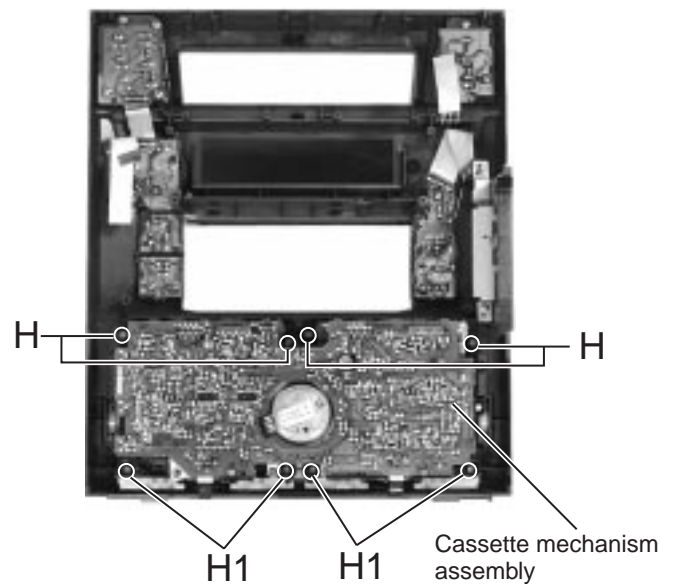
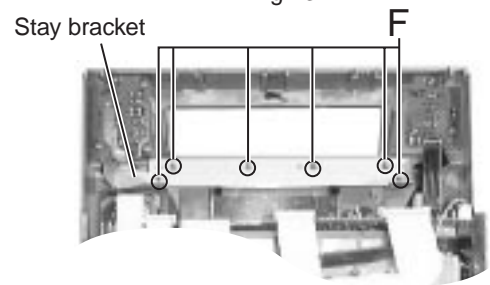
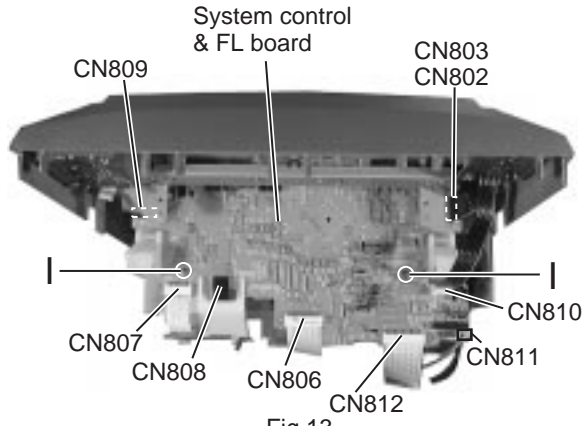

Fig.12

■ Removing the System Control & FL Board
(See Fig.13 and 14)

1. Disconnect the card wires and flat wires from connector CN807, CN808, CN806, CN812, CN810, CN803, CN802, CN809 on the system control & FL board respectively.
2. Disconnect the 2pin wire from connector CN811 on the system control & FL board.
3. Remove the six F screws attaching the stay bracket.
4. Remove the two I screws attaching the system control & FL board.



■ Removing Each Board of the Front Panel Assembly
(See Fig.15 and 16)

1. Disconnect the flat wire from connector CN810 on the system control & FL board on top of the rolling panel assembly.
2. Remove the three K screws attaching the power switch board.
3. Remove the two L screws attaching the phones board together with bracket.

* Remove the flat wire extending from the phones board through the slit of the rolling panel assembly.

4. Remove the four M screws attaching the CD eject board and unsolder the flat wire.

• Remove the rolling panel assembly.

5. Pull out the volume knob and nut toward the front.

6. Remove the two N screws attaching the volume board and unsolder the flat wire.

7. Remove the three O screws attaching the function board 1 and unsolder the flat wire.

8. Remove the four P screws attaching the function board 2.

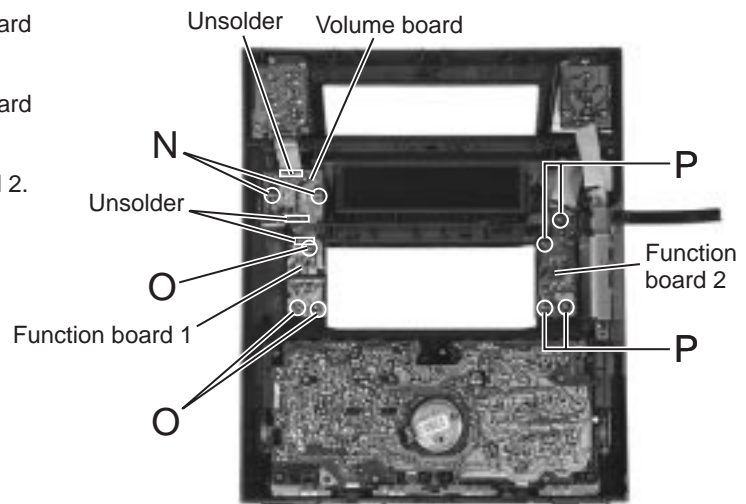
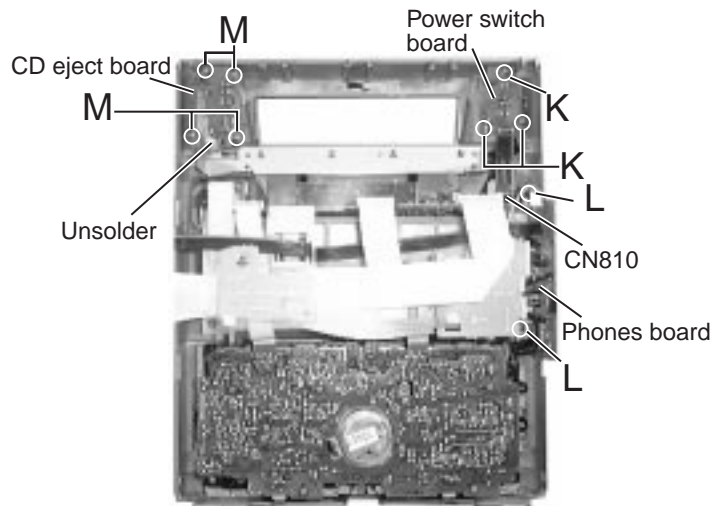

Fig.16

< Rear Panel Assembly >

- Prior to performing the following procedure, remove the metal cover and the CD changer mechanism assembly.
- The following procedure can be performed even if the front panel assembly is attached.

■ Removing the Rear Cover (See Fig.17)

1. Remove the two Q screws attaching the rear cover on the back of the body.

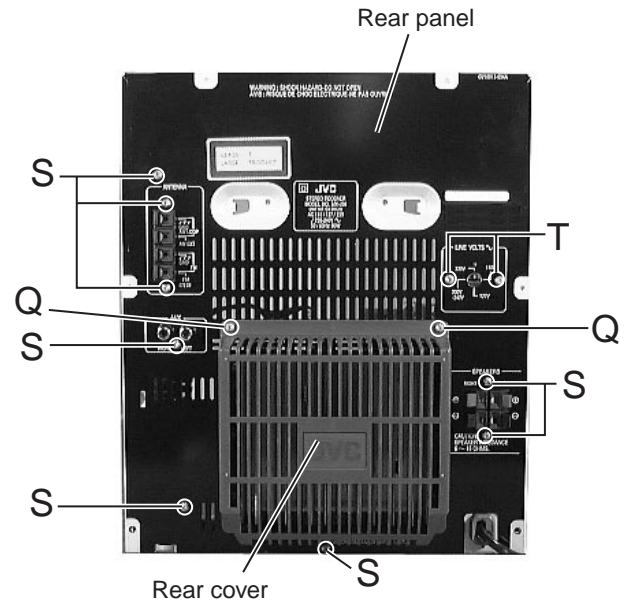

Fig.17

■ Removing the Rear Panel (See Fig.17 to 20)

- Prior to performing the following procedure, remove the rear cover.

1. Remove the four R screws attaching the heat sink and the rear panel.
2. Remove the eight S screws attaching the rear panel.
3. Remove the two T screws attaching the voltage selector and the rear panel. (Only Ver.U type)
4. Release the two joints(d) and (e) on the lower part of the rear panel using a screwdriver, and remove the rear panel toward the rear side.

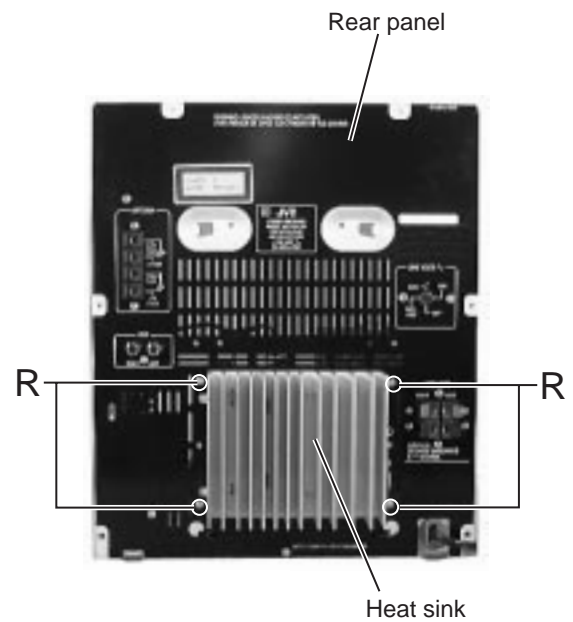

Fig.18

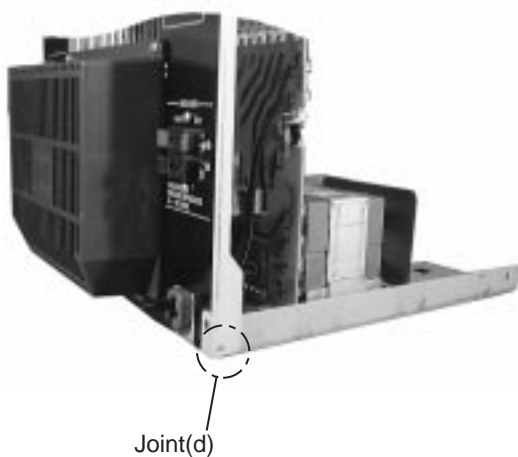

Fig.19

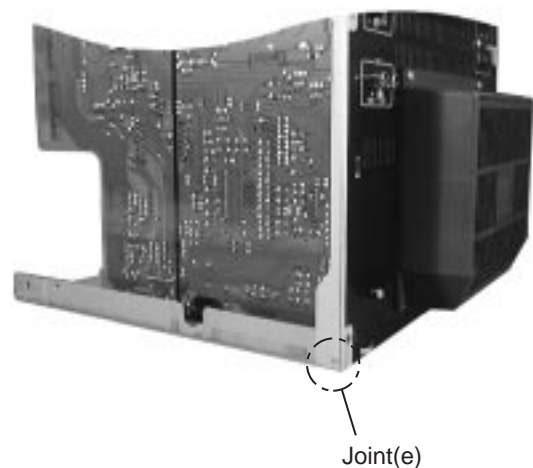

Fig.20

■ **Removing the Main Board** (See Fig.21 and 22)

- Prior to performing the following procedure, remove the metal cover, the CD changer mechanism assembly and the rear panel.

1. Disconnect the card wires from connector CN402, CN403 and CN416 on the main board and the flat wire from connector CN401.
2. Disconnect the flat wire from connector CN410 on the main board. (only Ver,U type)
3. Remove the screw U attaching the main board on the right side of the body.
4. Disconnect connector CN407 and CN408 under the main board, and remove the main board upward.

■ **Removing the Rated Voltage Board and Power Amplifier Board** (See Fig.21, 23 and 24)

- Prior to performing the following procedure, remove the metal cover, the CD changer mechanism assembly and the rear panel.

- The following procedure can be performed even if the front panel assembly is attached.

1. Disconnect the flat wire from connector CN212 on the power amplifier board.
2. Disconnect the flat wire from connector CN401 on the main board.
3. Pull out the rated voltage board and the power amplifier board upward from connector CN201 and CN204 on the power board respectively.
4. Remove the two V screws and two W screws attaching the heat sink together with the heat sink bracket.

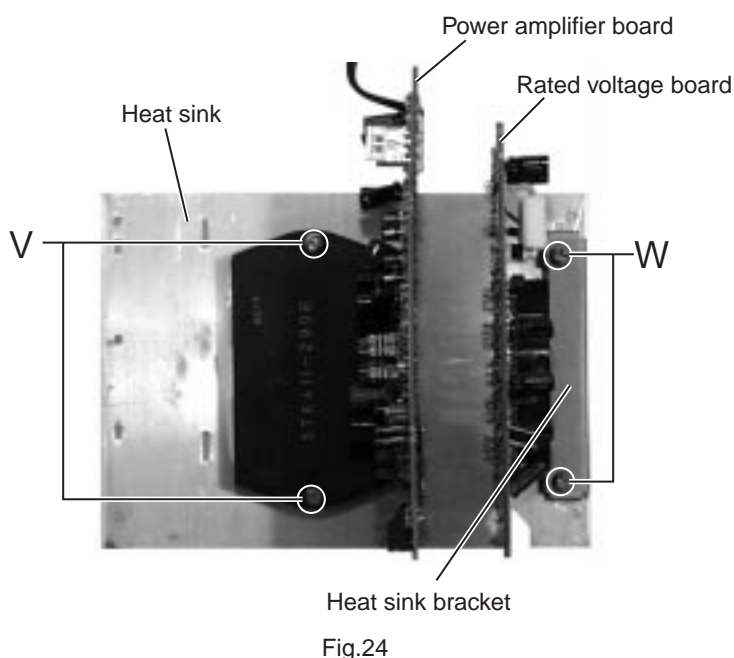
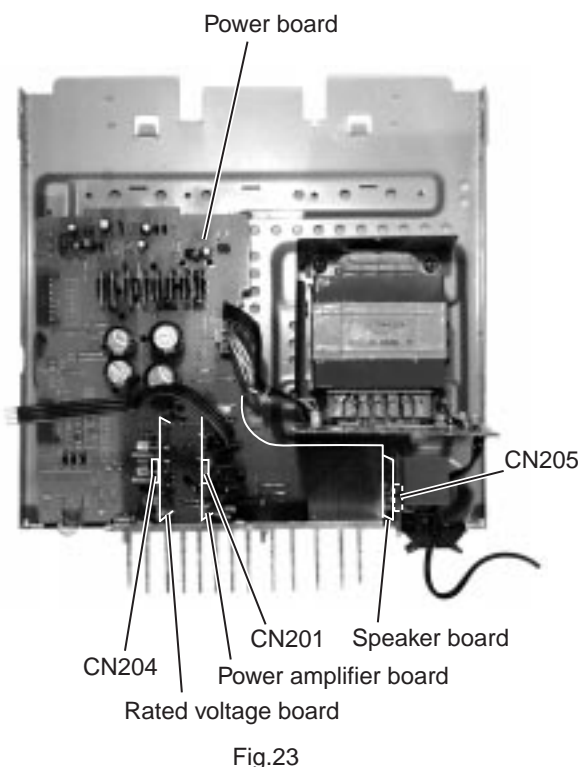
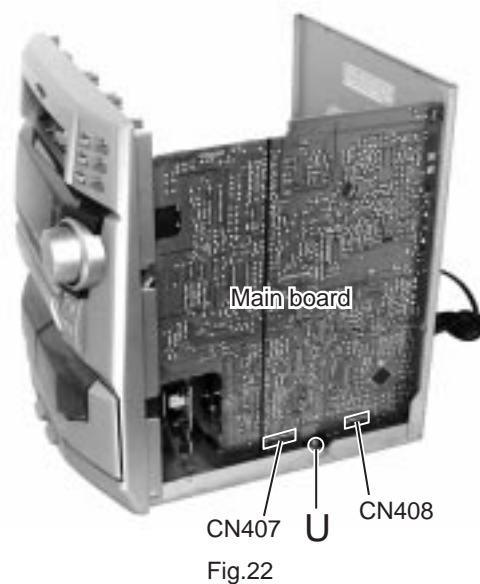
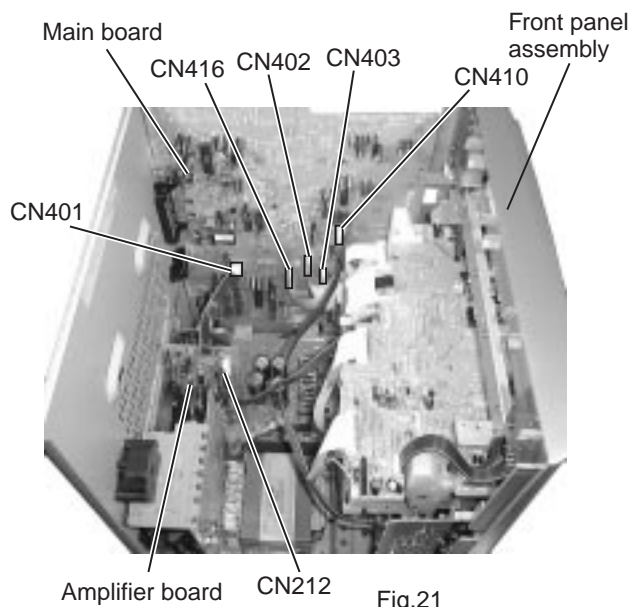

■ Removing the Speaker Board (See Fig.25)

- Prior to performing the following procedure, remove the metal cover, the CD changer mechanism assembly and the rear panel.
 - The following procedure can be performed even if the front panel assembly is attached.
1. Pull out the speaker board upward from connector CN205 on the power board.

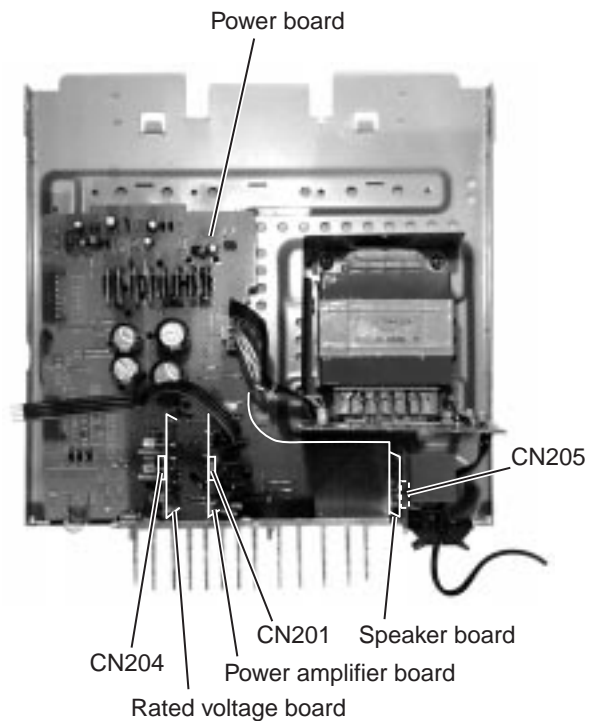

Fig.25

■ Removing the Power Transformer Board

(See Fig.26)

- Prior to performing the following procedure, remove the metal cover, the CD changer mechanism assembly and the rear panel.
1. Disconnect the 5P harness and the flat wire from connector CN206 and CN207 on the power board.
 2. Remove the four X screws attaching the power transformer assembly.
 3. Push the cord stopper upward to remove it.

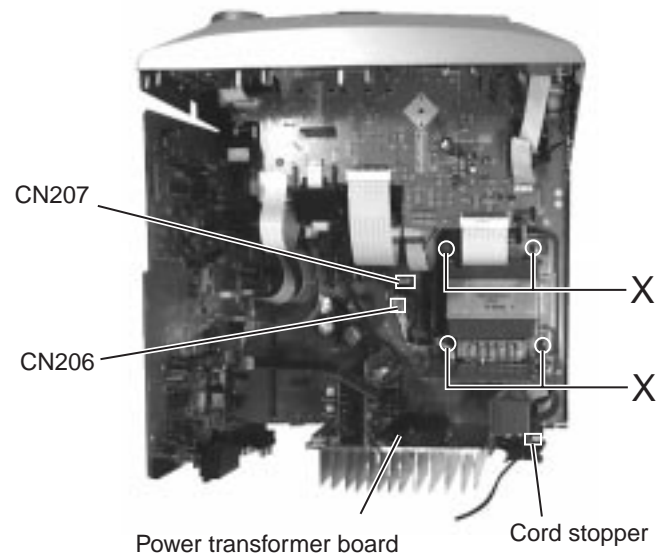

Fig.26

■ Removing the rolling Panel Assembly
(See Fig.27)

1. Remove the two Y screws attaching the rolling panel assembly.
2. Remove the rolling panel assembly while pulling outward the left and right hooks attaching the rolling panel assembly.

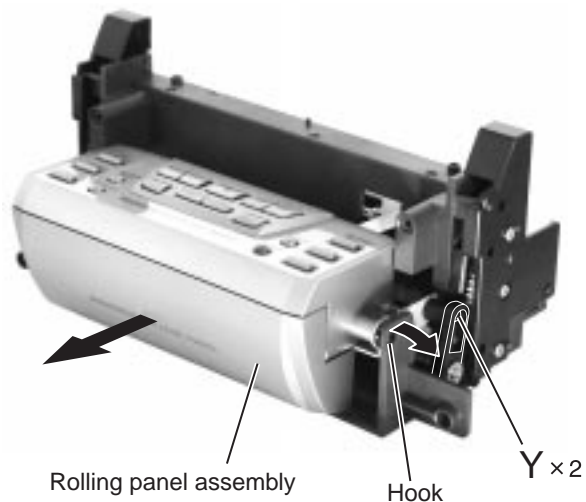

Fig.27

■ Removing the operation switch Board
(See Fig.28 and 29)

1. Remove the six Z screws attaching the cover and the bracket.
2. Release the two f tabs fitted to the bracket, and pull out the left and right panel holders.
3. Remove the two A screws attaching the operation switch board.

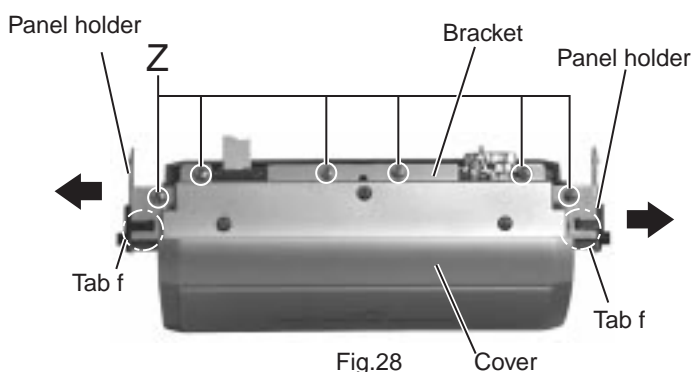

Fig.28

■ Removing the Drive Motor (See Fig.30 and 31)

1. Remove the two B screws and the two C screw attaching
2. Pull out the gear shaft A upward.
3. Remove the motor belt.

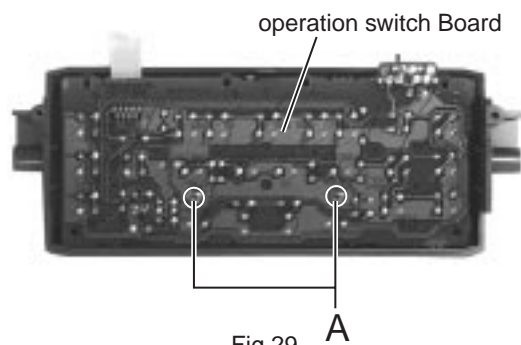

Fig.29

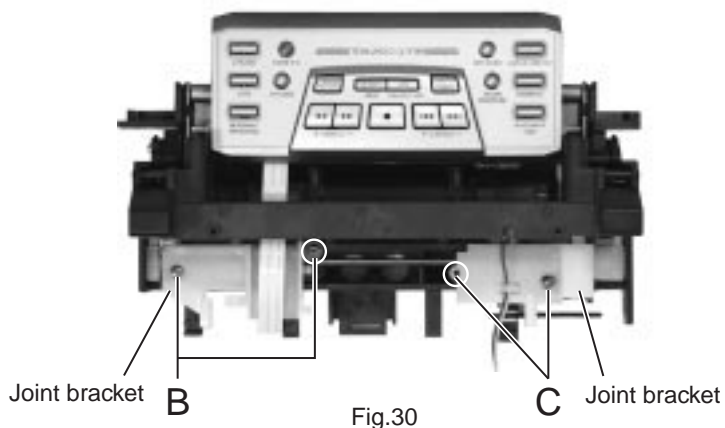

Fig.30

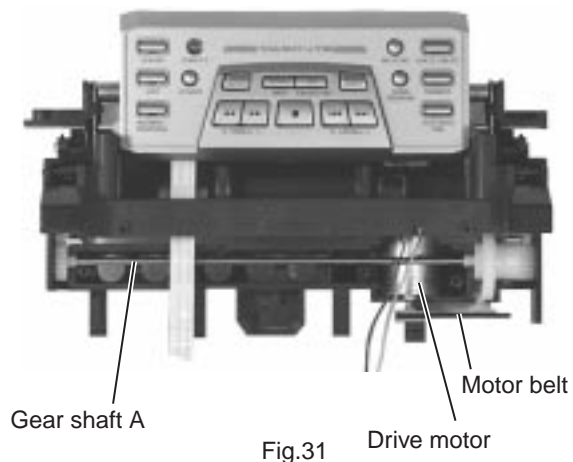

Fig.31

«CD Changer Mechanism Type:VC3 Section»

■ Removing the CD Servo control board (See Fig.1)

- 1.Remove the metal cover.
- 2.Remove the CD changer mechanism assembly.
- 3.From bottom side the CD changer mechanism assembly, remove the two screws 1 retaining the CD servo control board.
- 4.Absorb the four soldered positions "M" of the right and left motors with a soldering absorber.
- 5.Pull out the earth wire on the CD changer mechanism assembly.
- 6.The two screws A is removed and C.B.holder is detached.
- 7.Disconnect the connector CN854 on the CD servo control board.
- 8.Disconnect the card wire CN601 and the connector CN801 on the CD servo control board.

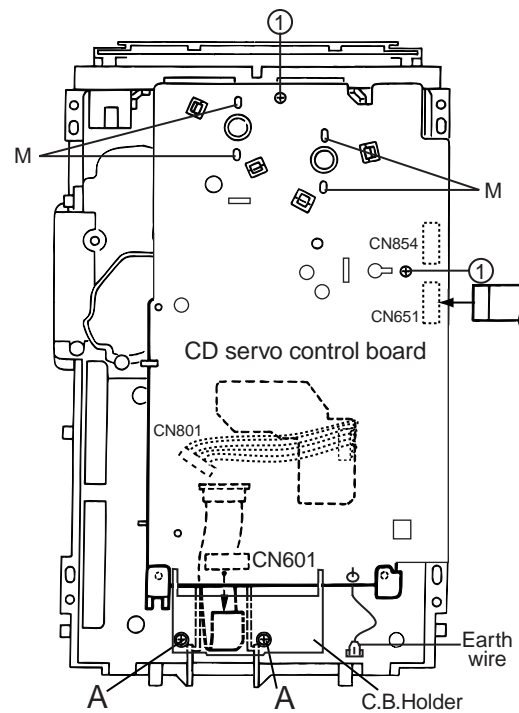

Fig.1

■ Removing the CD tray assembly (See Fig.2~4)

1. Remove the front panel assembly.
2. Remove the CD changer mechanism assembly.
3. Remove the CD Servo control board.
4. From the T.bracket section "B" and clamber base section "C", remove both of the edges fixing the rod(See Fig.2 and 3).
5. Remove the screw 2 retaining the Disc stopper (See Fig.3).
6. Remove the three screws 3 retaining the T.bracket (See Fig.3).
7. Remove the screws 4 retaining the clamber assembly (See Fig.3).
8. From the left side face of the chassis assembly, remove the one screw 5 retaining both of the return spring and lock lever(See Fig. 4).
9. By removing the pawl at the section "D" fixing the return spring, dismount the return spring(See Fig.4).
10. Remove the three lock levers(See Fig.4).

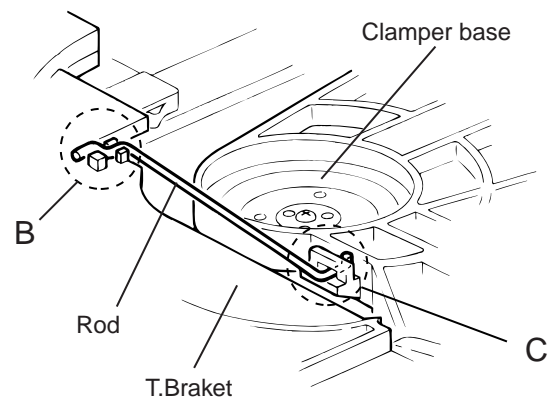

Fig.2

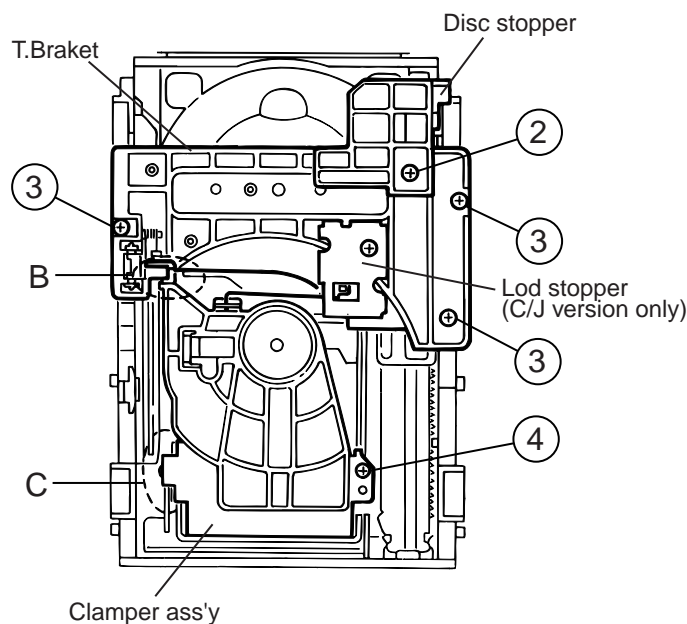

Fig.3

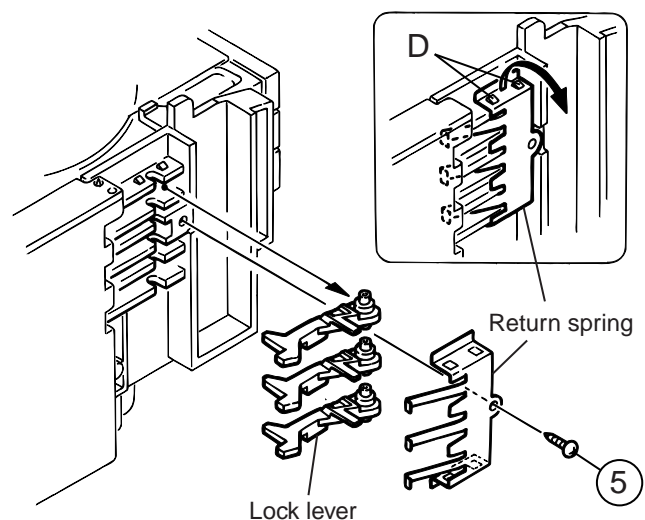

Fig.4

11. Check whether the lifter unit stopper has been caught into the hole at the section "E" of CD tray assembly as shown in Fig.5.
12. Make sure that the driver unit elevator is positioned as shown in Fig.6 from to the second or fifth hole on the left side face of the CD changer mechanism assembly.

[Caution] In case the driver unit elevator is not at above position, set the elevator to the position as shown in Fig.7 by manually turning the pulley gear as shown in Fig.8.

13. Manually turn the motor pulley in the clockwise direction until the lifter unit stopper is lowered from the section "E" of CD tray assembly(See Fig.8).
14. Pull out all of the three stages of CD tray assembly in the arrow direction "F" until these stages stop (See Fig.6).
15. At the position where the CD tray assembly has stopped, pull out the CD tray assembly while pressing the two pawls "G and G'" on the back side of CD tray assembly(See Fig.9). In this case, it is easy to pull out the assembly when it is pulled out first from the stage CD tray assembly.

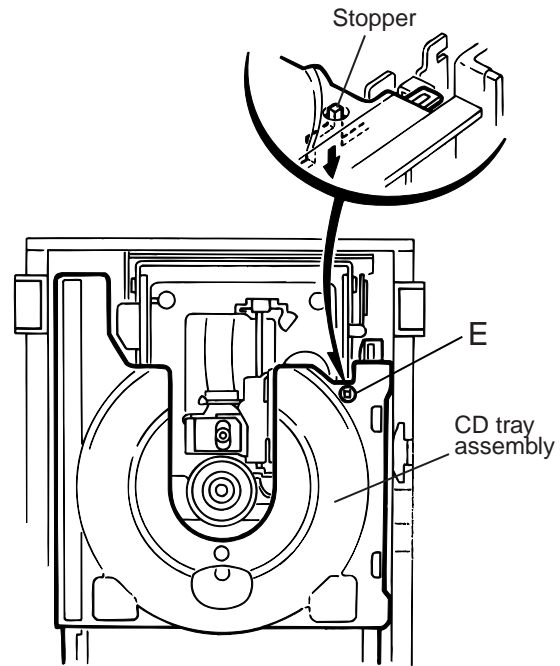

Fig.5

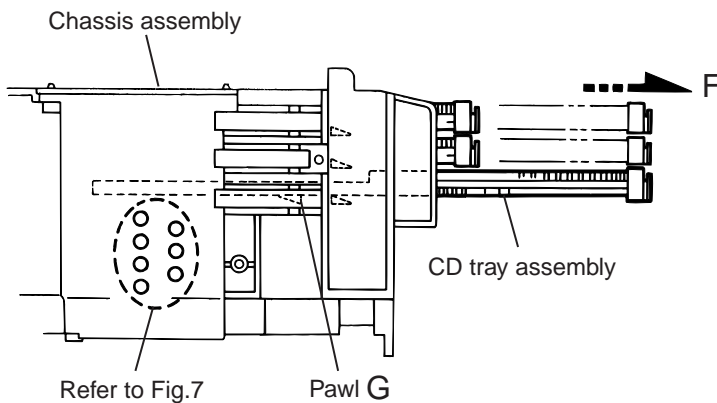

Fig.6

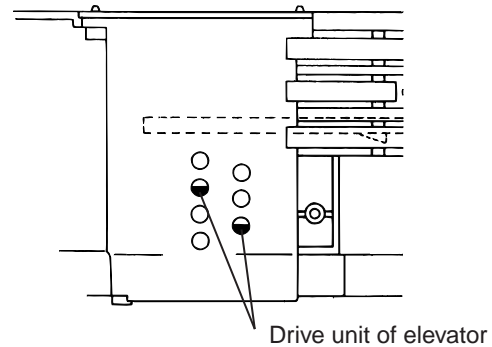

Fig.7

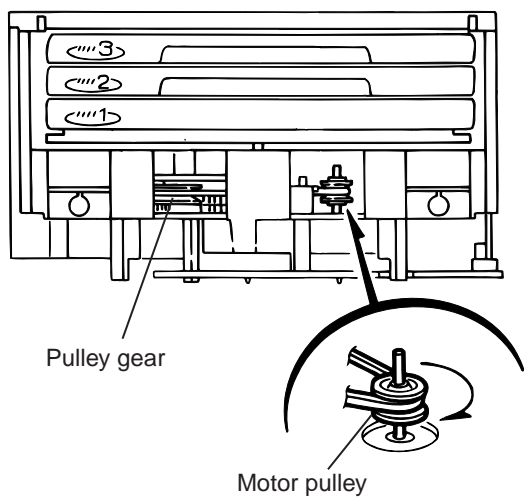

Fig.8

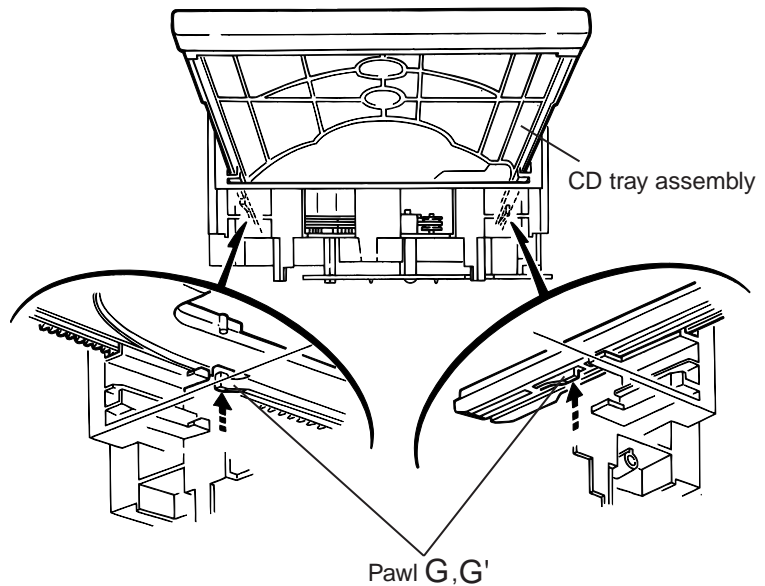

Fig.9

■ Removing the CD loading mechanism assembly (See Fig.10)

1. While turning the cams R1 and R2 assembly in the arrow direction "H", align the shaft "I" of the CD loading mechanism assembly to the position shown in Fig.10.
2. Fig.10.
Remove the four screws 6 retaining the CD loading mechanism assembly.

■ Removing the CD traverse mechanism (See Fig.11 and 12)

1. For dismantling only the CD traverse mechanism without removing the CD loading mechanism assembly, align the shaft "J" of the CD loading mechanism assembly to the position shown Fig.11 while turning the cam R1 and R2 assembly in the arrow direction "K".
2. By raising the CD loading mechanism assembly in the arrow direction "L", remove the assembly from the lifter unit.

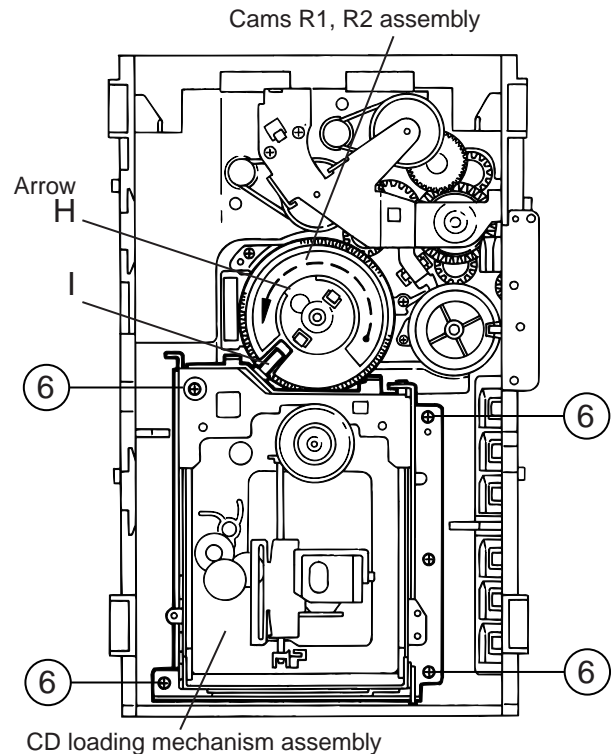

Fig.10

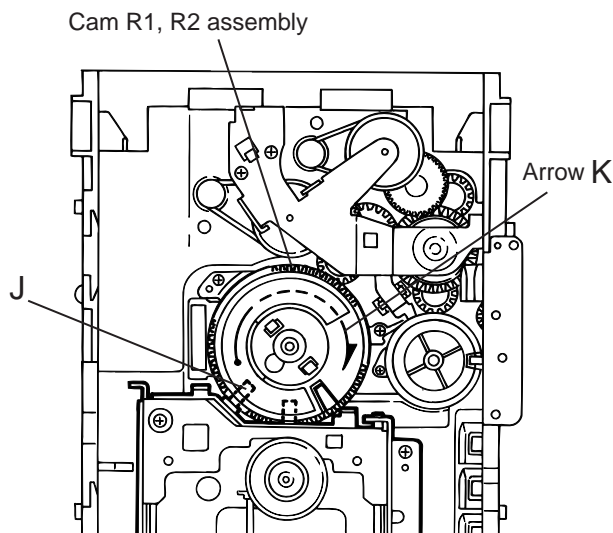

Fig.11

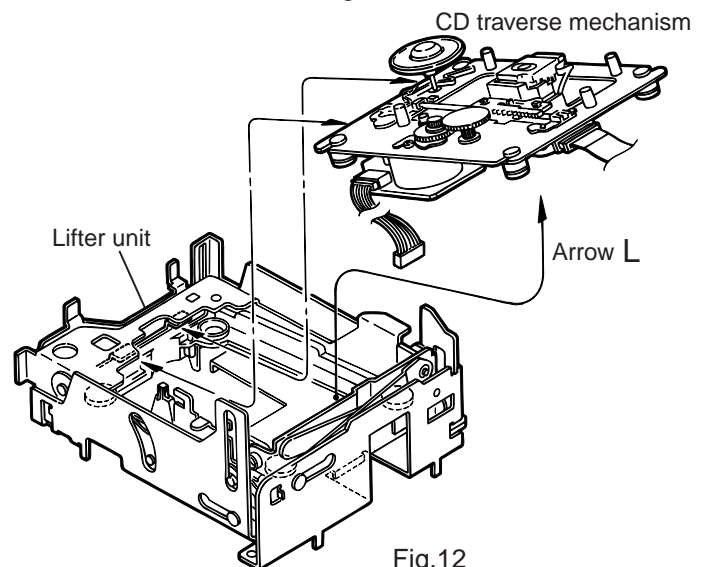

Fig.12

■ Removing the CD pick unit (See Fig.13)

1. Move the cam gear in the arrow direction a. Then, the CD pickup unit will be moved in the arrow direction b.
2. According to the above step, shift the CD pickup unit to the center position.
3. While pressing the stopper retaining the shaft in the arrow direction c, pull out the shaft in the arrow direction d.
4. After dismantling the shaft from the CD pickup unit, remove the CD pickup unit.

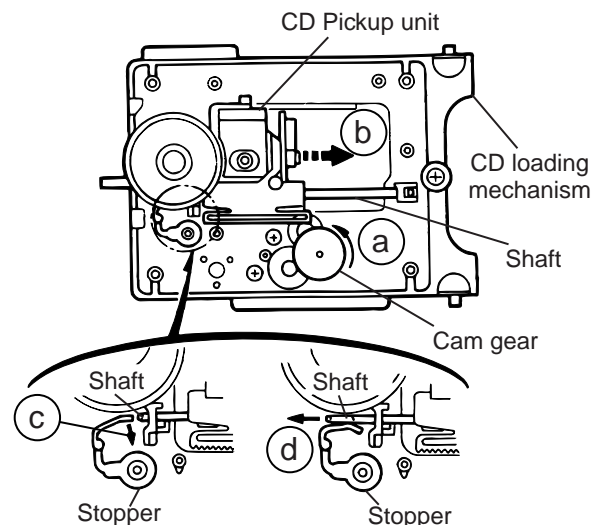

Fig.13

■ Removing the cam unit
(See Fig.14 ~ 17)

1. Remove the CD loading mechanism assembly.
2. While turning the cam gear L, align the pawl "N" position of the drive unit to the notch position(Fig.16) on the cam gear L.
3. Pull out the drive unit and cylinder gear(See Fig.17).
4. While turning the cam gear L, align the pawl "O" position of the select lever to the notch position(Fig.18) on the cam gear L.
5. Remove the four screws 9 retaining the cam unit(cam gear L and cams R1/R2 assembly)(See Fig.18).

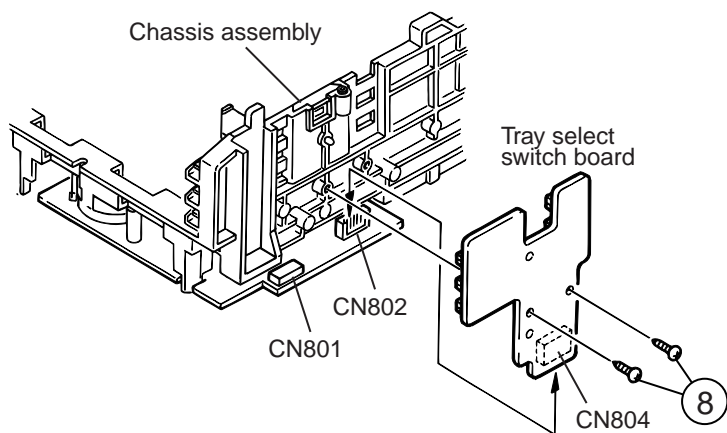

Fig.14

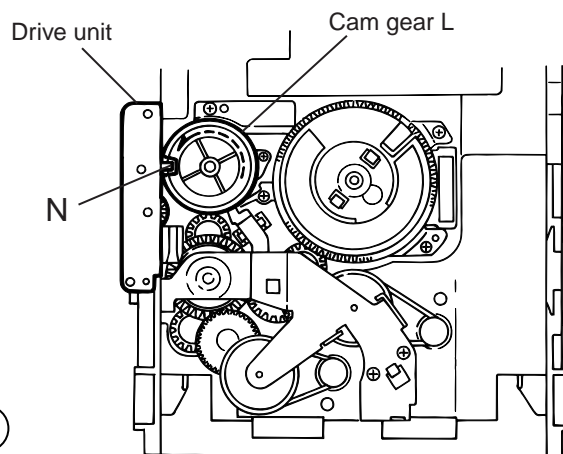

Fig.15

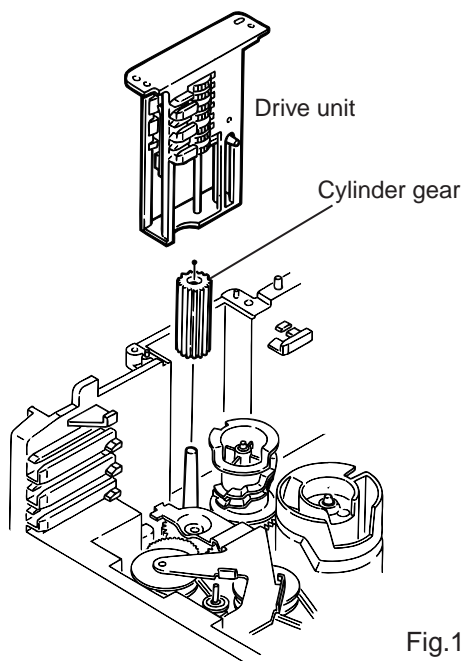

Fig.16

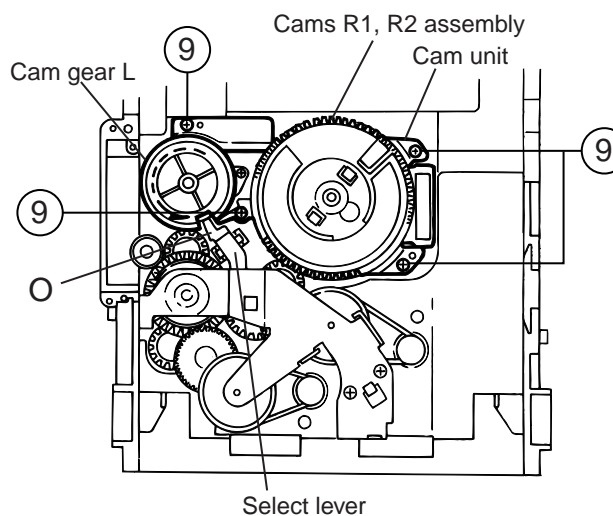

Fig.17

■Removing the actuator motor and belt (See Fig.18~21)

1. Remove the two screws 10 retaining the gear bracket
(See Fig.19).
2. While pressing the pawl "P" fixing the gear bracket in the arrow direction, remove the gear bracket
(See Fig.19).
3. From the notch "Q section" on the chassis assembly fixing the edge of gear bracket, remove and take out the gear bracket(See Fig. 20).
4. Remove the belts respectively from the right and left actuator motor pulleys and pulley gears(See Fig. 19).
5. After turning over the chassis assembly, remove the actuator motor while spreading the four pawls "R" fixing the right and left actuator motors in the arrow direction(See Fig. 21).

[Note] When the chassis assembly is turned over under the conditions wherein the gear bracket and belt have been removed, then the pulley gear as well as the gear, etc. constituting the gear unit can possibly be separated to pieces. In such a case, assemble these parts by referring to the assembly and configuration diagram in Fig. 22.

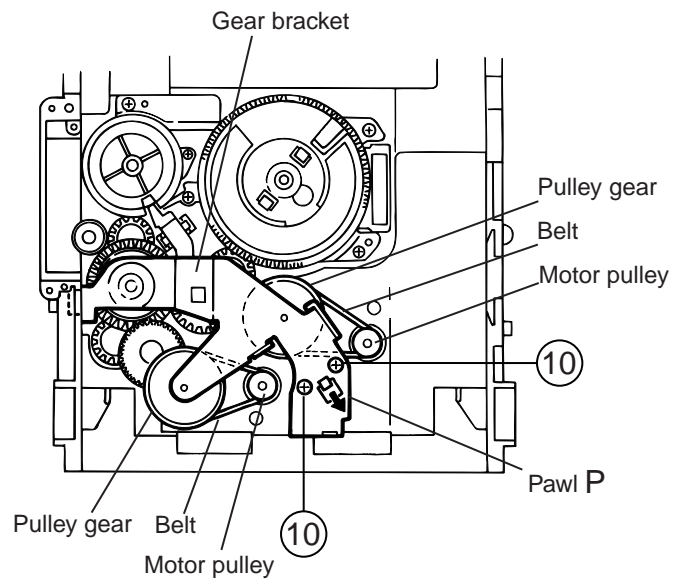

Fig.18

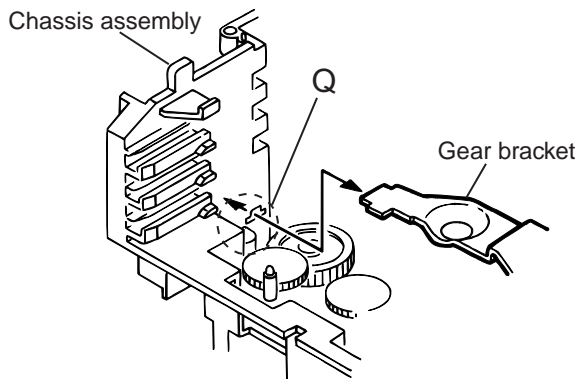

Fig.19

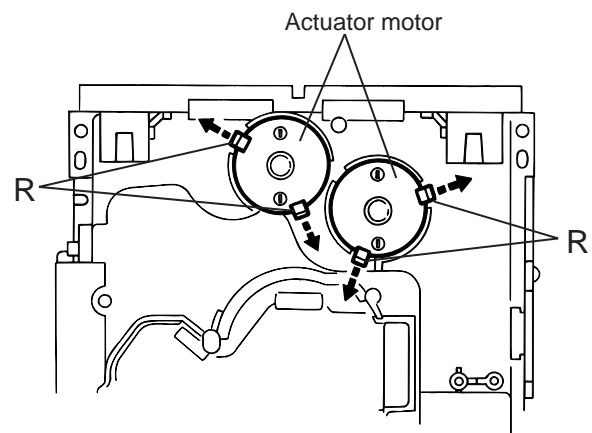

Fig.20

Assembly and Configuration Diagram

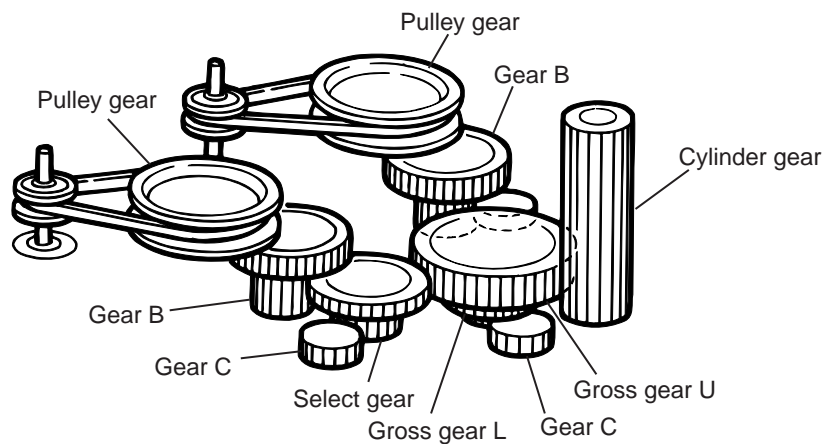

Fig.21

■ Removing the cams R1/R2 assembly and cam gear L (See Fig.22)

1. Remove the slit washer fixing the cams R1 and R2 assembly.
2. By removing the two pawls "S" fixing the cam R1, separate R2 from R1.
3. Remove the slit washer fixing the cam gear L.
4. Pull out the cam gear L from the C.G. base assembly.

■ Removing the C.G. base assembly (See Fig.22 and 23)

Remove the three screws 11 retaining the C.G. base assembly.

[Caution] To reassemble the cylinder gear, etc. with the cam unit (cam gear and cans R1/R2 assembly), gear unit and drive unit, align the position of the pawl "N" on the drive unit to that of the notch on the cam gear L. Then, make sure that the gear unit is engaged by turning the cam gear L (See Fig. 24).

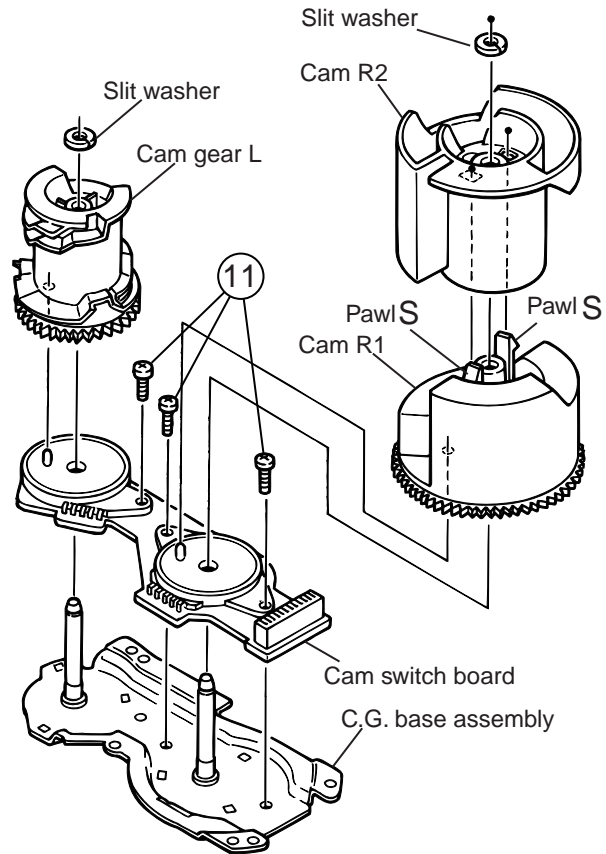

Fig.22

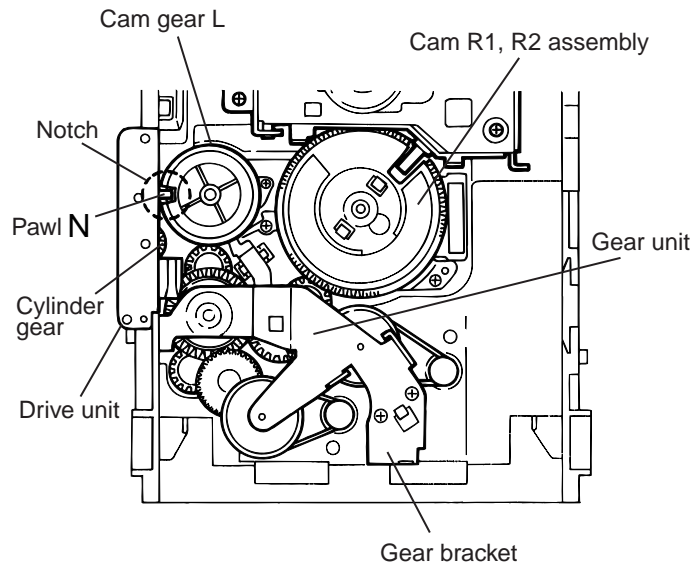

Fig.23

< Cassette Mechanism Section >

■ Removing the Playback, Recording and Eraser Heads

1. While shifting the trigger arms seen on the right side of the head mount in the arrow direction, turn the flywheel R in counterclockwise direction until the head mount has gone out with a click (See Fig 1).
2. When the flywheel R is rotated in counterclockwise direction, the playback head will be turned in counterclockwise direction from the position in Fig 2 to that in Fig 3.
3. At this position, disconnect the flexible P.C. board (outgoing from the playback head) from the connector CN301 on the head amp. and mechanism control P.C. board.
4. After dismantling the FPC holder, remove the flexible P.C. board.
5. Remove the flexible P.C. board from the chassis base.
6. Remove the spring "a" from behind the playback head.
7. Loosen the reversing azimuth screw retaining the playback head.
8. Take out the playback head from the front of the head mount.
9. The recording and eraser heads should also be removed similarly according to Steps 1~8 above.

● Reassembling the Playback, Recording and Eraser Heads

1. Reassemble the playback head from the front of the head mount to the position as shown in Fig 3.
2. Fix the reversing azimuth screw.
3. Set the spring a from behind the playback head.
4. Attach the flexible P.C. board to the chassis base, and fix it with the FPC holder as shown in Fig 3.
5. The recording and eraser heads should also be reassembled similarly according to Steps 1~4 above.

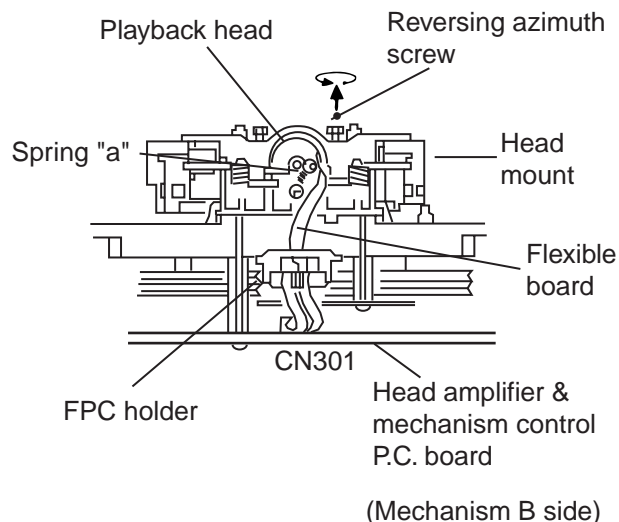
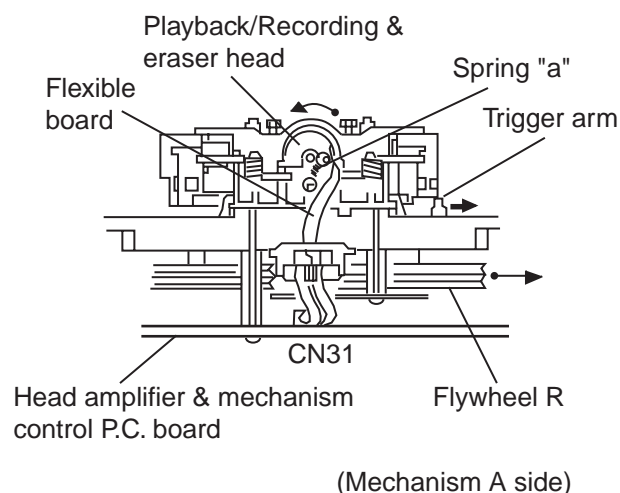
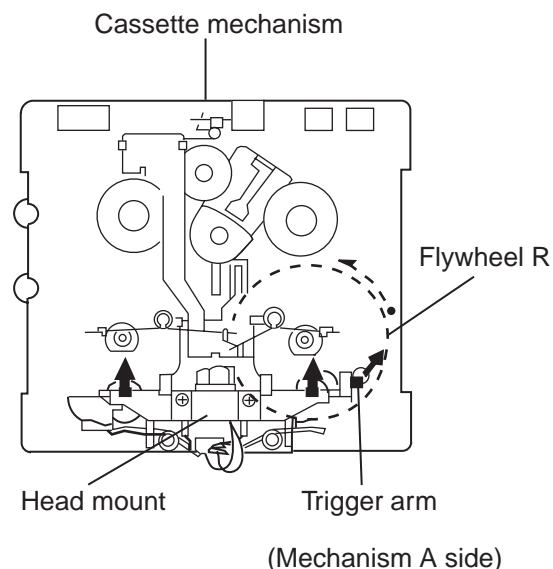

■ Removing the head Amp.and Mechanism Control P.C.Board (See Fig 4)

- 1.Remove the cassette mechanism assembly.
- 2.After turning over the cassette mechanism assembly,remove the five screws "A" retaining the head amp. and mechanism control P.C. board
- 3.Disconnect the connectors CN303 and CN304 on the P.C.Board and the connectors CN1 on both the right and left side reel pulse P.C.Boards.
- 4.When necessary, remove the 4pin parallel wire soldered to the main motor

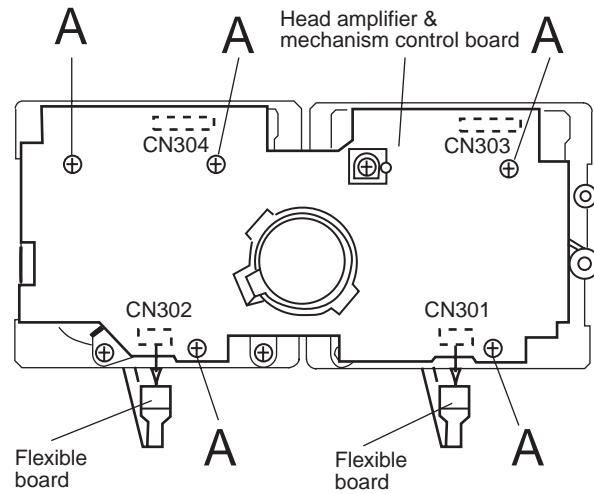

■ Removing the Capstan Motor Assembly

- 1.Remove the six screws "B" retaining capstan motor assembly (See Fig 5).
- 2.While raising the capstan motor, remove the capstan belts A and B respectively from the motor pulley (See Fig 6).

Caution 1: Be sure to handle the capstan belts so carefully that these belts will not be stained by grease and other foreign matter. Moreover, these belts should be hand while referring to the capstan belt hanging method.

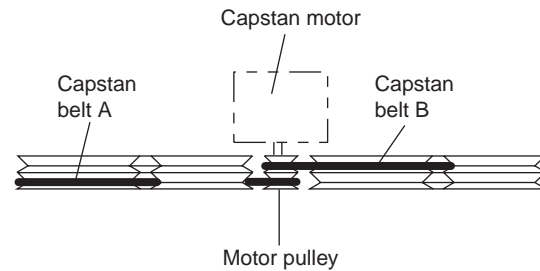
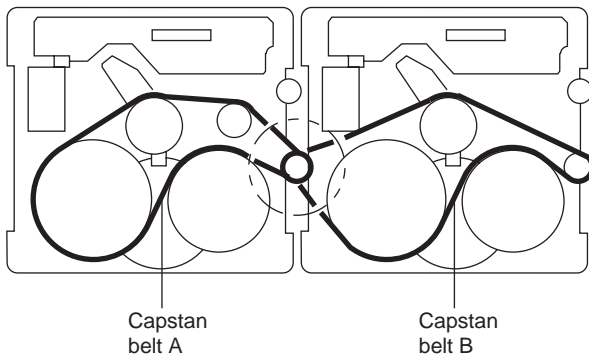
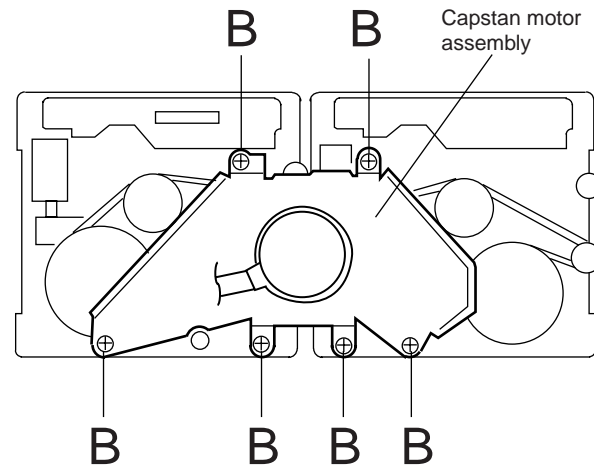

■ Removing the Capstan Motor (See Fig 8)

From the joint bracket, remove the two screws "C" retaining the capstan motor.

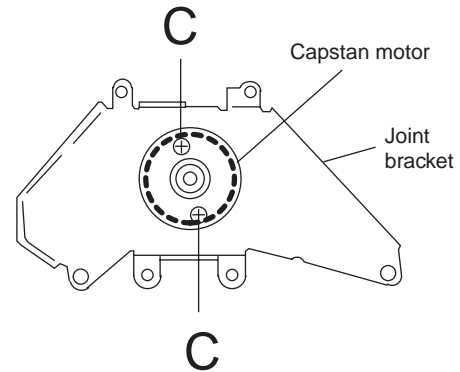

■ Removing the Flywheel (See Fig 9.10)

- 1.Remove the head amp. and mechanism control P.C.Board.
- 2.Remove the capstan motor assembly.
- 3.After turning over the cassette mechanism, remove the slit washers "a" and "b" fixing the capstan shafts R and L, and pull out the flywheels R and L respectively from behind the cassette mechanism.

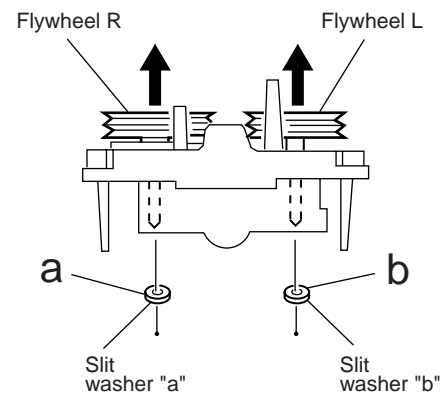
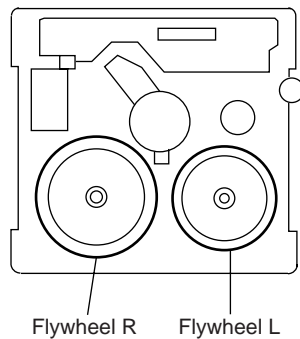

■ Removing the Reel Pulse P.C.Board and Solenoid (See Fig 11)

- 1.Remove the five pawls (c,d,e,f,g) retaining the reel pulse P.C.Board.
- 2.From the surface of the reel pulse P.C.Board parts, remove the two pawls "h" and "i" retaining the solenoid.

